

# Autonics High Accuracy PID Temperature Controller TK4 SERIES

## INSTRUCTION MANUAL



Thank you for choosing our Autonics product.  
Please read the following safety considerations before use.

### Safety Considerations

※Please observe all safety considerations for safe and proper product operation to avoid hazards.  
※⚠ symbol represents caution due to special circumstances in which hazards may occur.

- Warning** Failure to follow these instructions may result in serious injury or death.
- Caution** Failure to follow these instructions may result in personal injury or product damage.

### Warning

- Fail-safe device must be installed when using the unit with machinery that may cause serious injury or substantial economic loss.** (e.g. nuclear power control, medical equipment, ships, vehicles, railways, aircraft, combustion apparatus, safety equipment, crime/disaster prevention devices, etc.) Failure to follow this instruction may result in fire, personal injury, or economic loss.
- Install on a device panel to use.** Failure to follow this instruction may result in electric shock.
- Do not connect, repair, or inspect the unit while connected to a power source.** Failure to follow this instruction may result in electric shock or fire.
- Check "Connections" before wiring.** Failure to follow this instruction may result in fire.
- Do not disassemble or modify the unit.** Failure to follow this instruction may result in electric shock or fire.

### Caution

- When connecting the power input and relay output, use AWG 20 (0.50mm<sup>2</sup>) cable or over and tighten the terminal screw with a tightening torque of 0.74~0.90Nm.** When connecting the sensor input and communication cable without dedicated cable, use AWG 28~26 cable or over and tighten the terminal screw with a tightening torque of 0.74~0.90Nm. Failure to follow this instruction may result in fire or malfunction due to contact failure.
- Use the unit within the rated specifications.** Failure to follow this instruction may result in fire or product damage.
- Use dry cloth to clean the unit, and do not use water or organic solvent.** Failure to follow this instruction may result in electric shock or fire.
- Do not use the unit in the place where flammable/explosive/corrosive gas, humidity, direct sunlight, radiant heat, vibration, impact, or salinity may be present.** Failure to follow this instruction may result in fire or explosion.
- Keep metal chip, dust, and wire residue from flowing into the unit.** Failure to follow this instruction may result in fire or product damage.

### Ordering Information

TK	4	N	-1	4	R	N
OUT2 control output <sup>1)</sup>	Standard	N	None	※Select in case of standard control (heating or cooling)		
OUT1 control output <sup>2)</sup>	Heating & Cooling	R	Relay output			
Power supply	S <sup>3)</sup>	C	Current output or SSR drive output selectable			
	2 <sup>3)</sup>	4	100-240VAC 50/60Hz			
Input/Output option <sup>1)</sup>	1	Standard	Alarm output 1+CT input <sup>4)</sup>			
	2	Standard	Alarm output 1+Alarm output 2			
	N	D	Heating&Cooling Digital input (DI-1, DI-2)			
	R	T	Standard Alarm output 1+Transmission output			
	S	Standard	Alarm output 1+RS485 communication output			
	M	Standard	Alarm output 1+RS485 communication output			
	W	Standard	Alarm output 1+Transmission output			
	L	Standard	Alarm output 1+Alarm output 2+Transmission output			
	H	Standard	Alarm output 1+Alarm output 2+RS485 communication output			
	D	Standard	Alarm output 1+Alarm output 2+Digital input (DI-1, DI-2) <sup>5)</sup>			
Size	N	DIN W48×H24mm				
	SP	DIN W48×H48mm (11pin plug type) <sup>6)</sup>				
	S	DIN W48×H48mm (terminal block type)				
	M	DIN W72×H72mm				
	W	DIN W96×H48mm				
	H	DIN W48×H96mm				
	L	DIN W96×H96mm				
Digit	4	9999 (4-digit)				
Item	TK	Temperature / Process Controller				

- In case of TK4N/SP Series, option control selection and digital input will be limited due to number of terminals.
- "S" represents SSR drive output support models which SSR function (standard ON/OFF, cycle, phase) control are available. "C" represents selectable current and SSR drive output support models.
- Select "R" or "C" type in case of using heating&cooling control and "N" type in case of using standard control.
- Does not support in AC/DC voltage type model.
- Does not support in TK4N.
- The CT input model of TK4N is selectable only for standard model which has alarm output 1.
- The heating&cooling model of TK4N-1□□□ has only alarm output 2.
- Only for TK4S-D□□□, OUT2 output terminal is used as DI-2 input terminal.
- 11Pin socket (PG-11, PS-11(N)) for TK4SP: sold separately.

※Shaded descriptions are upgraded or added functions from the before TK Series.  
※The above specifications are subject to change and some models may be discontinued without notice.  
※Be sure to follow cautions written in the instruction manual, user manual and the technical descriptions (catalog, homepage).

### Specifications

Series	TK4N	TK4SP	TK4S	TK4M	TK4W	TK4H	TK4L
Power supply	AC voltage	100-240VAC~50/60Hz	—	—	—	—	—
Allowable voltage range	AC/DC voltage	—	24VAC~50/60Hz, 24-48VDC=	—	—	—	—
Power consumption	AC voltage	Max. 6VA	Max. 8VA	Max. 8VA	Max. 8VA	Max. 8VA	Max. 8VA
Display method	AC/DC voltage	—	Max. 8VA (24VAC 50/60Hz), max. 5W (24-48VDC)	—	—	—	—
Character size	7-segment (PV: red, SV: green, other display part: green, yellow, red) LED method	4.5×7.2mm	7.0×14.0mm	9.5×20.0mm	8.5×17.0mm	7.0×14.6mm	11.0×22.0mm
Input type	PV (W+H)	—	—	—	—	—	—
Display accuracy	SV (W+H)	—	—	—	—	—	—
Control output	RTD	JPT 100Ω, DPT 100Ω, DPT 50Ω, Cu 100Ω, Cu 50Ω, NiKel 120Ω (6 types)	—	—	—	—	—
Alarm output	Thermocouple	K, J, E, T, L, N, U, R, S, B, C, G, PLII (13 types)	—	—	—	—	—
Option output	Analog	—	—	—	—	—	—
Control method	RTD	—	—	—	—	—	—
Hyseteresis	Thermocouple	—	—	—	—	—	—
Proportional band (P)	Analog	—	—	—	—	—	—
Integral time (I)	CT input	—	—	—	—	—	—
Derivative time (D)	Relay	—	—	—	—	—	—
Control period (T)	SSR	—	—	—	—	—	—
Manual reset value	Current	—	—	—	—	—	—
Sampling period	Communication	—	—	—	—	—	—
Dielectric strength	CT	—	—	—	—	—	—
Vibration	Relay	—	—	—	—	—	—
Relay life cycle	Mechanical	—	—	—	—	—	—
Insulation resistance	Electrical	—	—	—	—	—	—
Noise immunity	Memory retention	—	—	—	—	—	—
Moisture retention	Environment	—	—	—	—	—	—
Protection	Insulation type	—	—	—	—	—	—
Approval	Weight <sup>1)</sup>	—	—	—	—	—	—

- At room temperature range (23°C±5°C):
  - Thermocouple K, J, T, N, E type, below -100°C / Thermocouple L, U, PLII, Cu50Ω, DPT 50Ω: (PV ±0.3% or ±2°C, select the higher one) ±1-digit
  - Thermocouple C, G, R, S type, below 200°C: (PV ±0.3% or ±3°C, select the higher one) ±1-digit
  - Thermocouple B type, below 400°C: there is no accuracy standards.
- Out of room temperature range:
  - RTD Cu50Ω, DPT50Ω: (PV ±0.5% or ±3°C, select the higher one) ±1-digit
  - Thermocouple R, S, B, C, G type: (PV ±0.5% or ±5°C, select the higher one) ±1-digit
- Others, below -100°C: within ±5°C
- In case of TK4SP Series, ±1°C will be added to the degree standard.
- ※The weight includes packaging. The weight in parenthesis is for unit only.
- ※Environment resistance is rated at no freezing or condensation.

### Unit Description

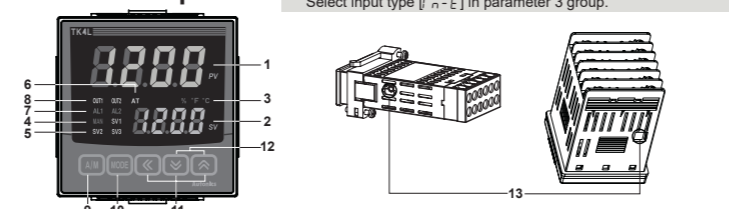

- Measured value (PV) display part:** RUN mode: It displays currently measured value (PV). Setting mode: It displays the parameter.
- Set value (SV) display part:** RUN mode: It displays the set value (SV). Setting mode: It displays the set value of the parameter.
- Unit (%C/F%) indicator:** It displays the unit set at display unit [unit] in parameter 3 group. (In case of TK4N, % is not supported).
- Manual control indicator:** It turns ON during manual controlling.
- Multi SV indicator:** One of SV1 to 3 lamps will be ON in case of selecting multi SV function.
- Auto tuning indicator:** It flashes by 1 sec. when executing auto tuning.
- Alarm output (AL1, AL2) indicator:** It turns ON when the alarm output is ON.
- Control output (OUT1, OUT2) indicator:** It turns ON when the control output is ON.
  - ※During cycle/phase controlling in SSRP function model (TK4□□4S□□), when MV is over 5.0%, it turns ON.
  - ※To use current output, when MV is 0.0% in manual control, it turns OFF. Otherwise, it always turns ON.
  - When MV is over 3.0% in auto control, it turns ON and when MV is below 2.0%, it turns OFF.
- Key:** It is used when switching auto control to manual control.
- TK4N/S/SP** do not have the key. The key operates switching simultaneously.
- key:** It is used when entering parameter groups, returning to RUN mode, moving parameter, saving the set value.
- key:** It is used when entering the set value changing mode and moving or changing up/down digit.
- Digital input key:** When pressing key + key for 3 sec. at the same time, it operates the function (RUN/STOP, alarm clear, auto tuning) set at digital input key [di - v] in parameter 5 group.
- PC loader port:** It is the PC loader port for serial communication to set parameter with DAQMaster installed in PC. Use this for connecting SCM-US (USB/Serial converter, sold separately).

### Installation

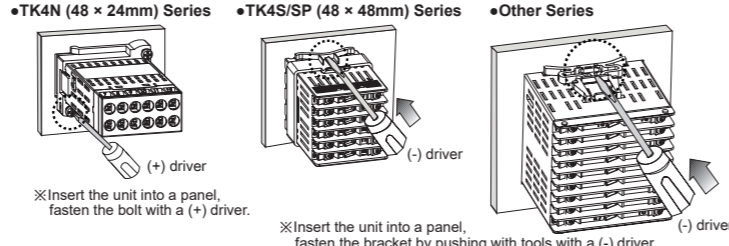

### Connections

※Standard model has shaded terminals only.  
※When the operation mode of heating&cooling OUT2 relay output model is heating or cooling control, the OUT2 is usable as alarm output 3 (except TK4N Series).  
※When the operation mode of heating&cooling OUT2 current output model is heating or cooling control, the OUT2 is usable as transmission output 2.  
※Use terminals of size specified below.

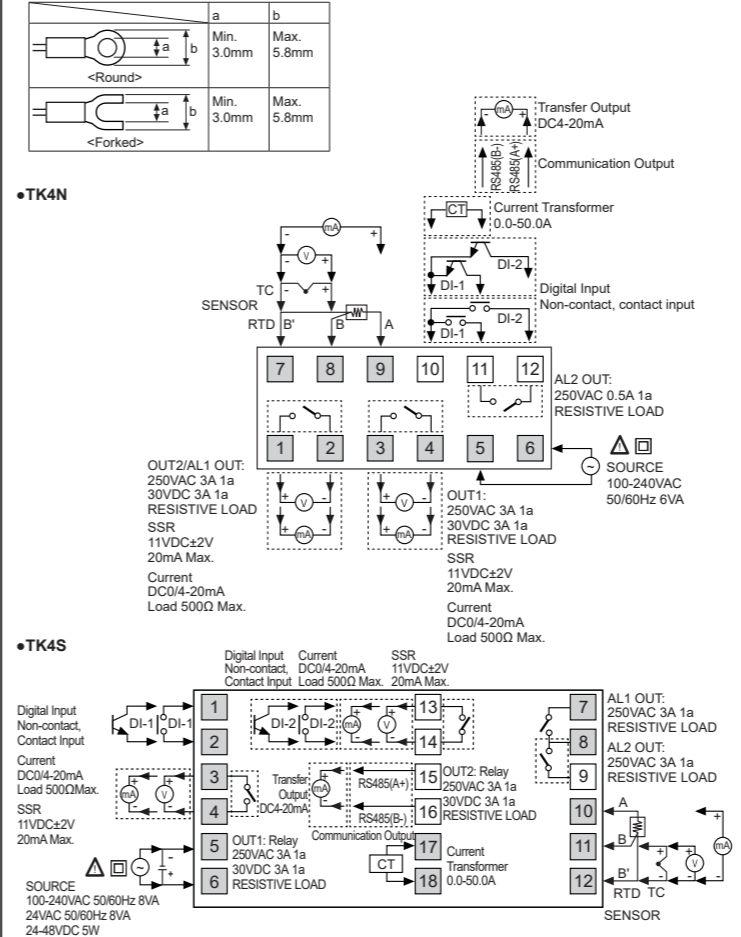

### Dimensions

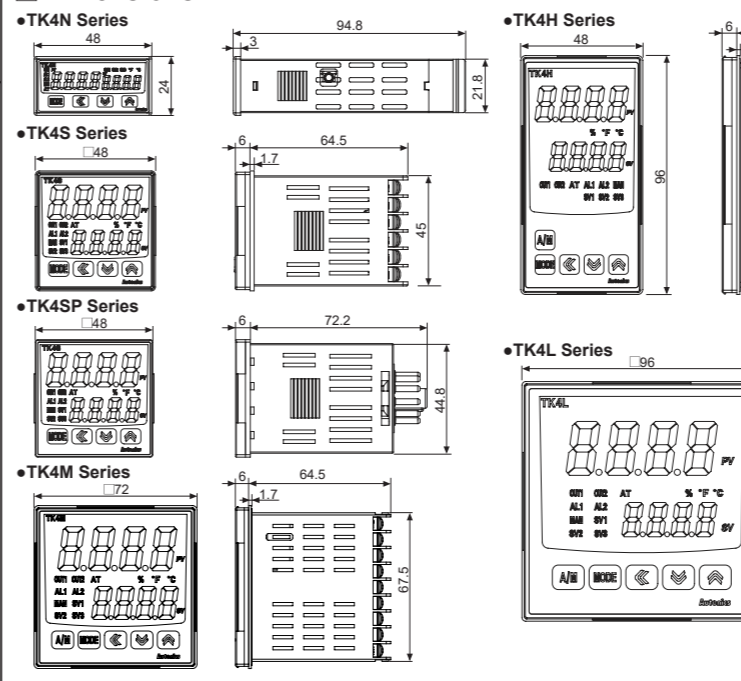

### Bracket

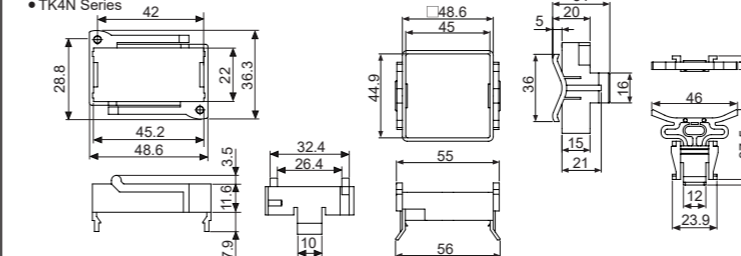

### TK4SP

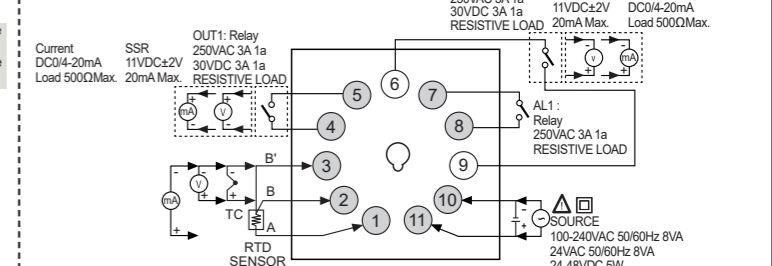

### TK4M

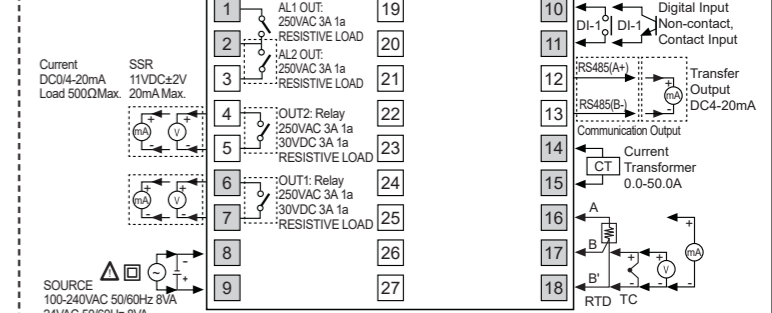

### TK4H, TK4W, TK4L

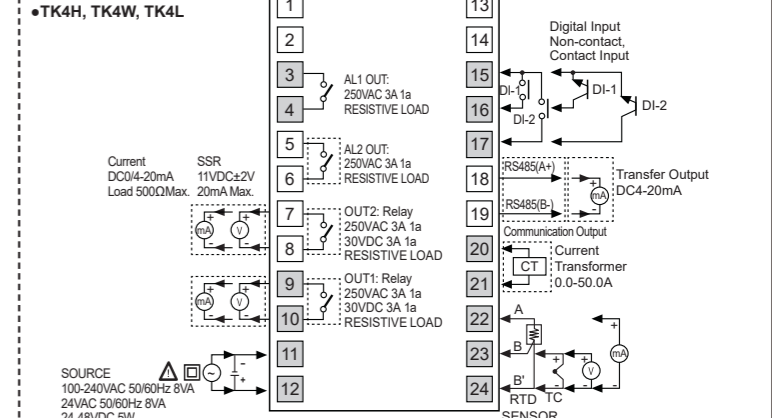

### Terminal cover (sold separately)

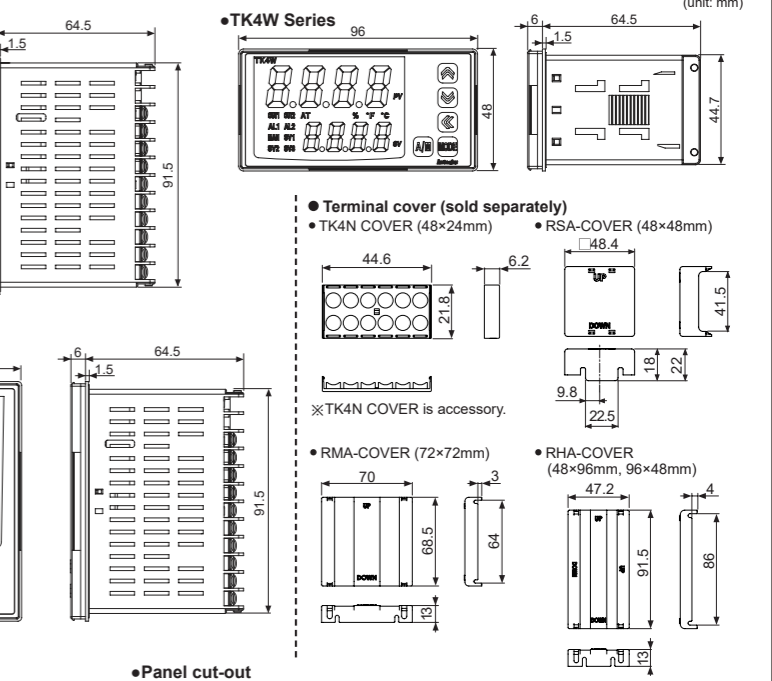

### Panel cut-out

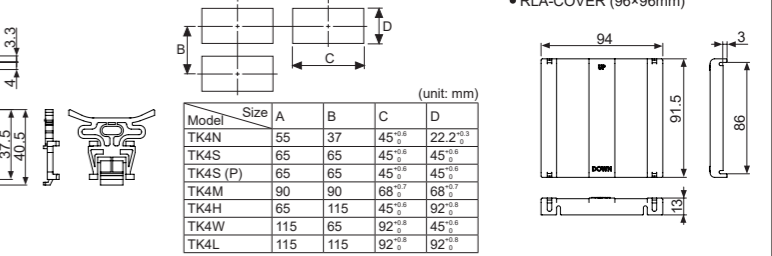

## Flow Chart for Setting Group

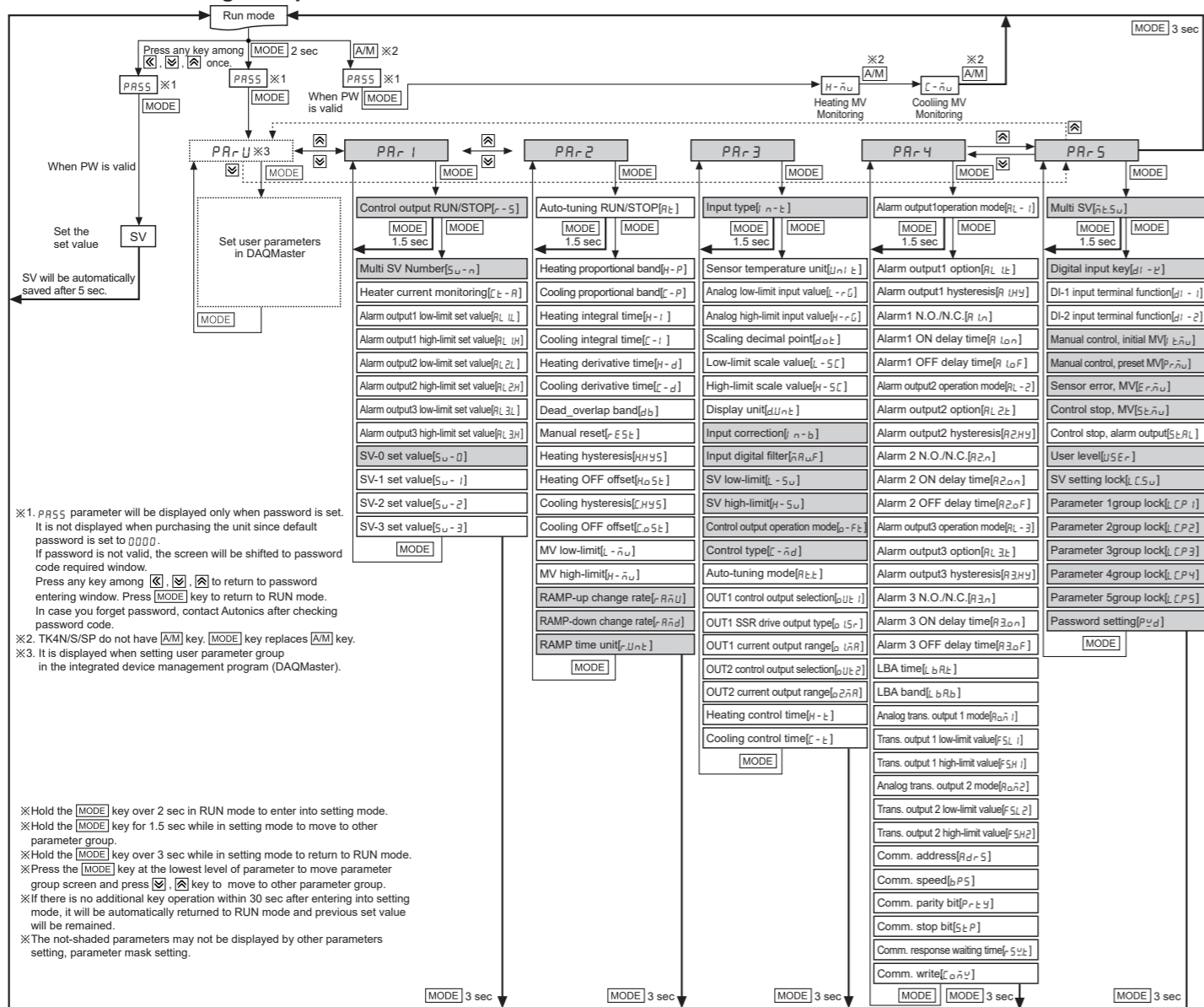

※1. PR55 parameter will be displayed only when password is set. It is not displayed when purchasing the unit since default password is set to 0000. If password is not valid, the screen will be shifted to password code required window. Press any key among [OK], [MODE], [PR55] to return to password entering window. Press [MODE] key to return to RUN mode. In case you forget password, contact Autonics after checking password code.

※2. TK4N/SP do not have [AM] key. [MODE] key replaces [AM] key.

※3. It is displayed when setting user parameter group in the integrated device management program (DAQMaster).

※Hold the [MODE] key over 2 sec in RUN mode to enter into setting mode.

※Hold the [MODE] key for 1.5 sec while in setting mode to move to other parameter group.

※Hold the [MODE] key over 3 sec while in setting mode to return to RUN mode.

※Press the [MODE] key at the lowest level of parameter to move parameter group screen and press [PR55] key to move to other parameter group.

※If there is no additional key operation within 30 sec after entering into setting mode, it will be automatically returned to RUN mode and previous set value will be remained.

※The not-shaded parameters may not be displayed by other parameters setting, parameter mask setting.

## Input Types and Range

Input type	Decimal point	Display	Input range (°C)	Input range (°F)
Thermocouple	K (CA)	1	-200 to 1350	-328 to 2463
	J (IC)	0.1	-199.9 to 999.9	-328 to 1472
	E (CR)	0.1	-199.9 to 800.0	-328 to 1472
	T (CC)	1	-200 to 400	-328 to 752
	B (PR)	1	-199.9 to 400.0	-328 to 752.0
	R (PR)	1	0 to 1800	32 to 3272
	S (PR)	1	0 to 1750	32 to 3182
	N (NN)	1	0 to 1750	32 to 3182
	C (TT) <sup>※1</sup>	1	-200 to 1300	-328 to 2372
	G (TT) <sup>※2</sup>	1	0 to 2300	32 to 4172
RTD	L (IC)	0.1	-200 to 900	-328 to 1652
	U (CC)	0.1	-199.9 to 900.0	-328 to 1652.0
	Platinel II	1	-199.9 to 400.0	-328 to 752.0
	Cu 50Ω	0.1	-199.9 to 200.0	-328 to 392.0
	Cu 100Ω	0.1	-199.9 to 200.0	-328 to 392.0
	JPt 100Ω	1	-200 to 650	-328 to 1202
	DPT 50Ω	0.1	-199.9 to 650.0	-328 to 1202.0
	DPT 100Ω	0.1	-199.9 to 650.0	-328 to 1202.0
	Nickel 120Ω	1	-200 to 650	-328 to 1202
	Analog	Voltage	0-10V	RA1
0-5V		RA2	(Display point will be changed according to decimal point position.)	
1-5V		RA3		
0-100mV		RA4		
Current	0-20mA	RA5		
4-20mA	RA6			

※1: C (TT): Same temperature sensor as former W5 (TT)  
 ※2: G (TT): Same temperature sensor as former W (TT)

## Initial Display When Power ON

When power is supplied, whole display parts flash for 1 sec. Afterwards, model name and input sensor type will be flash twice and then it enters into RUN mode.

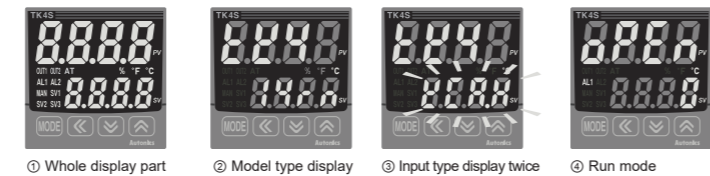

## Set Value (SV) Setting

You can set the temperature to control with [OK], [MODE], [PR55] keys. Set range is within SV low-limit value [L - 5u] to SV high-limit value [H - 5u].

Ex) In case of changing set temperature from 210°C to 250°C.

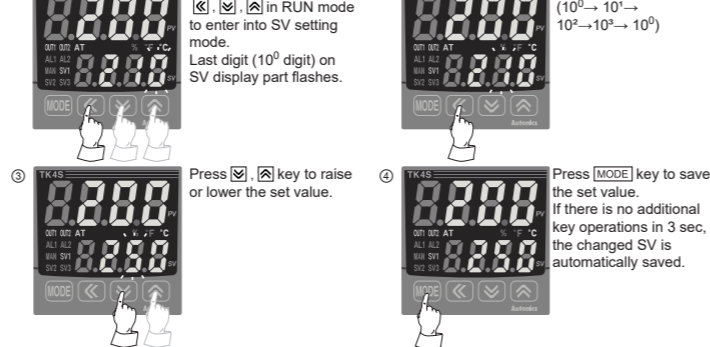

## Parameter Reset

Press [OK] + [MODE] + [PR55] to reset all parameters in memory to default value. Set [n1] parameter to '4E5' to reset all parameters. In case password function is on, it is required to enter valid password to reset parameters. Password is also reset.

## Parameter Mask

This function is able to hide unnecessary parameters to user environment or less frequently used parameters in parameter group. You can set this in the integrated device management program (DAQMaster). Masked parameters are not only displayed. The set value of masked parameters are applied. For more information, refer to the DAQMaster user manual. Visit our website (www.autonics.com) to download the DAQMaster program and the user manual.

Before applying mask: PR2 → RL → H-P → C-P → H-I → C-I → H-d → C-d

After applying mask: PR2 → H-P → H-I → H-d

The above is masking auto tuning [n1], cooling proportional band [C-P], cooling integral time [C-I], cooling derivative time [C-d] parameters in parameter 2 group.

## User Parameter Group [PR-U] Setting

This function is able to set the frequently used parameters to the user parameter group. You can quickly and easily set parameter settings. User parameter group can have up to 30 parameters in the integrated device management program (DAQMaster). For more information, refer to the DAQMaster user manual. Visit our website (www.autonics.com) to download the DAQMaster program and the user manual.

### Run mode

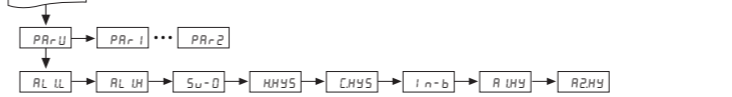

The above is setting user parameter group in the DAQMaster with alarm output 1 low-limit value [RL 1], alarm output 1 high-limit value [RL 1H], SV-0 set value [5u-0] parameter of parameter 1 group, heating hysteresis [H45], cooling hysteresis [C45] parameters of parameter 2 group, input correction [n-b] parameter of parameter 3 group, alarm output 1 hysteresis [A1H], alarm output 2 hysteresis [A2H] parameters of parameter 4 group.

## Auto-tuning

Auto-tuning measures the control subject's thermal characteristics and thermal response rate, and then determines the necessary PID time constant. Application of the PID time constant realizes fast response and high precision temperature control. (When setting control type [C-d] is set as P, it is displayed.) Set [n1] parameter to [n1] in parameter 2 group to start auto-tuning. To stop auto-tuning, change the set as [oFF]. (It maintains P, I, D values of before auto-tuning.) If sensor break error [bPE] occurs during auto-tuning, it stops this operation. If the measured temperature is over or below the input range, it operates continuously. During auto-tuning operation, whole parameters are only available to check.

## Alarm

### Alarm operation

Mode	Name	Alarm operation	Description
oFF	—	—	No alarm output
dUCC	Deviation high-limit alarm	OFF   H   ON SV PV 100°C 110°C High deviation: Set as 10°C High deviation: Set as -10°C	If deviation between PV and SV as high-limit is higher than set value of deviation temperature, the alarm output will be ON.
JJdU	Deviation low-limit alarm	ON   H   OFF PV SV 90°C 100°C Low deviation: Set as 10°C Low deviation: Set as -10°C	If deviation between PV and SV as low-limit is higher than set value of deviation temperature, the alarm output will be ON.
JdUc	Deviation high/low-limit alarm	ON   H   OFF   H   ON PV SV PV SV 90°C 100°C 120°C Low deviation: Set as 10°C, High deviation: Set as 20°C	If deviation between PV and SV as high/low-limit is higher than set value of deviation temperature, the alarm output will be ON.
CdUJ	Deviation high/low-limit alarm	OFF   H   ON   H   OFF PV SV PV SV 90°C 100°C 120°C Low deviation: Set as 10°C, High deviation: Set as 20°C	If deviation between PV and SV as high/low-limit is lower than set value of deviation temperature, the alarm output will be OFF.
PuCC	Absolute value high-limit alarm	OFF   H   ON   H   ON PV SV PV SV 90°C 100°C Absolute-value: Set as 90°C Absolute-value: Set as 110°C	If PV is higher than the absolute value, the output will be ON.
JJPu	Absolute value low-limit alarm	ON   H   OFF   H   OFF PV SV PV SV 90°C 100°C Absolute-value: Set as 90°C Absolute-value: Set as 110°C	If PV is lower than the absolute value, the output will be ON.
LbA	Loop break alarm	—	It will be ON when it detects loop break.
5bA	Sensor break alarm	—	It will be ON when it detects sensor disconnection.
HbA	Heater break alarm	—	It will be ON when CT detects heater break.

※H: Alarm output [ ] hysteresis [A□H]

### Alarm option

Mode	Name	Description
RL - A	Standard alarm	If it is an alarm condition, alarm output is ON. If it is a clear alarm condition, alarm output is OFF.
RL - b	Alarm latch	If it is an alarm condition, alarm output is ON and maintains ON status.
RL - C	Standby sequence 1	First alarm condition is ignored and from second alarm condition, standard alarm operates. When power is supplied and it is an alarm condition, this first alarm condition is ignored and from the second alarm condition, standard alarm operates.
RL - d	Alarm latch and standby sequence 1	If it is an alarm condition, it operates both alarm latch and standby sequence. When power is supplied and it is an alarm condition, this first alarm condition is ignored and from the second alarm condition, alarm latch operates.
RL - E	Standby sequence 2	First alarm condition is ignored and from second alarm condition, standard alarm operates. When re-applied standby sequence and if it is alarm condition, alarm output does not turn ON. After clearing alarm condition, standard alarm operates.
RL - F	Alarm latch and standby sequence 2	Basic operation is same as alarm latch and standby sequence 1. It operates not only by power ON/OFF, but also alarm set value, or alarm option changing. When re-applied standby sequence and if it is alarm condition, alarm output does not turn ON. After clearing alarm condition, alarm latch operates.

※Condition of re-applied standby sequence for standby sequence 1, alarm latch and standby sequence 1: Power ON  
 Condition of re-applied standby sequence for standby sequence 2, alarm latch and standby sequence 2: Power ON, changing set temperature, alarm temperature [RL 1, RL 2] or alarm operation [RL - 1, RL - 2], switching STOP mode to RUN mode.

## Factory Default

### SV setting group [5u]

Parameter	Factory default
5u	0

### Password input parameter

Parameter	Factory default
PR55	0001

### Parameter 1 group [PR-1]

Parameter	Factory default	Parameter	Factory default	Parameter	Factory default	Parameter	Factory default
r-5	rUn	RL 1H	1550	RL 3H	1550	5u-3	0000
5u-n	5u-0	RL 2L	1550	5u-0	0000		
Ct-A	00	RL 2H	1550	5u-1	0000		
RL 1L	1550	RL 3L	1550	5u-2	0000		

### Parameter 2 group [PR-2]

Parameter	Factory default	Parameter	Factory default	Parameter	Factory default	Parameter	Factory default
Ae	oFF	H-d	0000	H-o5t	000	rAnU	000
H-P	0.100	C-d	0000	C45	002	rAnH	000
C-P	0.100	db	0000	C-o5t	000	rAnL	n1 n
H-I	0000	rE5t	0500	L-nu	-1000		
C-I	0000	H45	002	H-nu	1000		

### Parameter 3 group [PR-3]

Parameter	Factory default	Parameter	Factory default	Parameter	Factory default	Parameter	Factory default
i n-t	ECRH	H-5C	1000	o-Ft	HEAt	o15r	5tnd
Un1t	oC	dUnL	o'0	H-C	H-C	o1AR	4-20
L-rG	0000	i n-b	0000	C-nD	P1 d	oUe2	CUr
H-rG	1000	nRuF	0001	PP	o2nA	4-20	
d-oE	00	L-5u	-200	AEt	tUn1	H-t	0200 (Relay)
L-5C	0000	H-5u	1350	oUe1	CUr	C-t	0020 (SSR)

### Parameter 4 group [PR-4]

Parameter	Factory default	Parameter	Factory default	Parameter	Factory default	Parameter	Factory default
RL - 1	dUCC	A2n	no	LbAb	0000	bP5	95
RL 1H	AL - A	A2on	0000	LbAb	002	P-rY	noE
RL 1L	001	A2oF	0000	Ao-n1	Pu	5tP	2
A ln	no	AL - 3	oFF	F5L1	-200	r54t	20
A loA	0000	AL 3t	AL - A	F5H1	1350	C-nY	EnA
A loF	0000	A3HY	001	Ao-n2	Pu		
RL - 2	JJdU	A3n	no	F5L2	-200		
RL 2t	AL - A	A3on	0000	F5H2	1350		
A2HY	001	A3oF	0000	A-d-5	01		

### Parameter 5 group [PR-5]

Parameter	Factory default	Parameter	Factory default	Parameter	Factory default	Parameter	Factory default
nE5u	1	P-rnu	0000	LCSu	oFF	LCPS	oFF
di - 5	5toP	Er-nu	0000	LCPI	oFF	P-yd	0000
di - 1	oFF	5tAu	0000	LCPI	oFF		
di - 2	oFF	5tAL	0000	LCPI	oFF		
L-tAu	RUto	U5Er	5tnd	LCPI	oFF		

※Shaded parameters are for the heating&cooling model.

## User Manual

For the detail information and instructions, please refer to user manual and user manual for communication, and be sure to follow cautions written in the technical descriptions (catalog, homepage). Visit our homepage (www.autonics.com) to download manuals.

## Comprehensive Device Management Program[DAQMaster]

DAQMaster is a comprehensive device management software for setting parameters and monitoring processes. DAQMaster can be downloaded from our website at www.autonics.com.

Item	Minimum specifications
System	IBM PC compatible computer with Pentium III or above
Operations	Windows 98/NT/XP/Vista/7/8/10
Memory	256MB+
Hard disk	1GB+ of available hard disk space
VGA	Resolution: 1024×768 or higher
Others	RS232C serial port (9-pin), USB port

## Cautions during Use

- Follow instructions in 'Cautions during Use'. Otherwise, it may cause unexpected accidents.
- Check the polarity of the terminals before wiring the temperature sensor.
- For RTD temperature sensor, wire it as 3-wire type, using cables in same thickness and length. For thermocouple (CT) temperature sensor, use the designated compensation wire for extending wire.
- Keep away from high voltage lines or power lines to prevent inductive noise. In case installing power line and input signal line closely, use line filter or varistor at power line and shielded wire at input signal line.
- Do not use near the equipment which generates strong magnetic force or high frequency noise.
- Do not apply excessive power when connecting or disconnecting the connectors of the product.
- Install a power switch or circuit breaker in the easily accessible place for supplying or disconnecting the power.
- Do not use the unit for other purpose (e.g. voltmeter, ammeter), but temperature controller.
- When changing the input sensor, turn off the power first before changing.
- After changing the input sensor, modify the value of the corresponding parameter.
- 24VAC, 24-48VDC power supply should be insulated and limited voltage/current or Class 2, SELV power supply device.
- Do not overlapping communication line and power line.
- Use twisted pair wire for communication line and connect ferrite bead at each end of line to reduce the effect of external noise.
- Make a required space around the unit for radiation of heat.
- For accurate temperature measurement, warm up the unit over 20 min after turning on the power.
- Make sure that power supply voltage reaches to the rated voltage within 2 sec after supplying power.
- Do not wire to terminals which are not used.
- This unit may be used in the following environments.
  - ①Indoors (in the environment condition rated in 'Specifications')
  - ②Altitude max. 2,000m
  - ③Pollution degree 2
  - ④Installation category II

## Major Products

- Photoelectric Sensors
- Fiber Optic Sensors
- Door Sensors
- Door Side Sensors
- Area Sensors
- Proximity Sensors
- Pressure Sensors
- Rotary Encoders
- Connector/Sockets
- Switching Mode Power Supplies
- Control Switches/Lamps/Buttons
- I/O Terminal Blocks & Cables
- Stepper Motors/Drivers/Motion Controllers
- Graphic/Logic Panels
- Field Network Devices
- Laser Marking System (Fiber, CO<sub>2</sub>, Nd:YAG)
- Laser Welding/Cutting System
- Temperature Controllers
- Temperature/Humidity Transducers
- SSRs/Power Controllers
- Counters
- Timers
- Panel Meters
- Tachometer/Pulse (Rate) Meters
- Display Units
- Sensor Controllers

**Autonics corporation**  
<http://www.autonics.com>

■ HEADQUARTERS:  
 18, Bansong-ro 513beon-gil, Haendae-gu, Busan, South Korea, 48002  
 TEL: 82-51-519-3232  
 E-mail: sales@autonics.com

DRW170598AB

## High Performance, General-Purpose, PID Control Temperature Controller

### ■ Features

- 50ms high-speed sampling rate and  $\pm 0.3\%$  display accuracy
- Simultaneous heating and cooling control function
- Automatic/manual control option
- Switch between current output and SSR drive output
- SSR drive output (SSRP function) control options:  
ON/OFF control, cycle control, phase control
- Communication output models available:  
RS485 (Modbus RTU)
- Parameter configuration via PC  
(RS485 communication)
  - DAQMaster software included (comprehensive device management software)
  - Communication converter sold separately
    - : SCM-WF48 (Wi-Fi to RS485-USB wireless communication converter),
    - SCM-US48I (USB to RS485 converter), SCM-38I (RS232C to RS485 converter),
    - SCM-US (USB to serial converter)
- User-friendly parameter features (via DAQMaster)
- SV preset function (up to 4 set values) using digital input terminals
- Heater disconnect alarm function (CT input)
  - Current transformer (CT) sold separately: CSTC-E80LN, CSTC-E200LN, CSTS-E80PP
- Various input types and temperature ranges



**⚠ Please read "Safety Considerations" in the instruction manual before using.**



### ■ Manual

- For the detail information and instructions, please refer to the user manual and user manual for communication, and be sure to follow cautions written in the technical descriptions (catalog, website).  
Visit our website ([www.autonics.com](http://www.autonics.com)) to download manuals.
- User manual describes for specifications and function, and communication manual describes for RS485 communication (Modbus RTU protocol) and parameter address map data.

### ■ Comprehensive Device Management Program (DAQMaster)

- DAQMaster is comprehensive device management program. It is available for parameter setting, monitoring, and user parameter group setting, parameter mask setting for only TK4 Series.
- Visit our website ([www.autonics.com](http://www.autonics.com)) to download user manual and comprehensive device management program.

< Computer specification for using software >

Item	Minimum requirements
System	IBM PC compatible computer with Intel Pentium III or above
Operating system	Microsoft Windows 98/NT/XP/Vista/7/8/10
Memory	256MB or more
Hard disk	More than 1GB of free hard disk space
VGA	1024×768 or higher resolution display
Others	RS-232 serial port (9-pin), USB port

< DAQMaster screen >

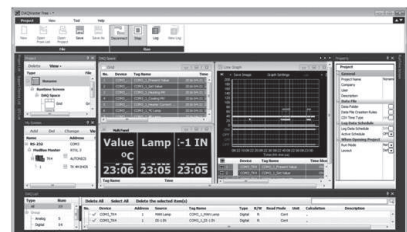

- SENSORS
- CONTROLLERS
- MOTION DEVICES
- SOFTWARE
- (J) Temperature Controllers
- (K) SSRs
- (L) Power Controllers
- (M) Counters
- (N) Timers
- (O) Digital Panel Meters
- (P) Indicators
- (Q) Converters
- (R) Digital Display Units
- (S) Sensor Controllers
- (T) Switching Mode Power Supplies
- (U) Recorders
- (V) HMIs
- (W) Panel PC
- (X) Field Network Devices

# TK Series



























## Ordering Information

TK	4	S	—	1	4	R	R
							OUT 2 control output <sup>※9</sup>
							OUT 1 control output <sup>※7</sup>
							Power supply
							Option input/output <sup>※2</sup>
							Size
							Digit
							Item
							Standard
							Heating & Cooling <sup>※10</sup>
							R
							S <sup>※8</sup>
							C
							2 <sup>※6</sup>
							4
							1
							2
							D
							R
							T
							SP
							1
							2
							R
							T
							A
							B
							D
							N
							SP
							S
							M
							W
							H
							L
							4
							TK

- ※1. 11Pin socket(PG-11, PS-11(N)): Sold separately
- ※2. In case of TK4N/TK4SP Series, option control output selection and digital input will be limited due to number of terminals.
- ※3. The CT input model of TK4N is selectable only for standard model which has alarm 1.
- ※4. The Heating & Cooling model of TK4N-1□□□ has only alarm output 2.
- ※5. Only for TK4S-D□□□, OUT2 output terminal is used as DI-2 input terminal.
- ※6. Does not support in TK4N.
- ※7. "S" represents SSR drive output support models which SSRP function (standard ON/OFF, cycle, phase)control are available. "C" represents selectable current and SSR drive output support models.
- ※8. Does not support in AC/DC voltage type model.
- ※9. Select "R" or "C" type in case of using heating & cooling control. "N" type in case of using standard control.
- ※10. In case of Relay OUT2 model, alarm output 3 is available only when control output operation mode [o - F t] is set heating [H e R t] or cooling [c o o l]. In case of current output, trans. output 2 is available only when control output operation mode [o - F t] is set heating [H e R t] or cooling [c o o l].

# High Performance, General-Purpose, PID Control

## Specifications

Series		TK4N	TK4SP	TK4S	TK4M	TK4W	TK4H	TK4L
Power supply	AC voltage	100-240VAC~ 50/60Hz						
	AC/DC voltage	—   24VAC~ 50/60Hz, 24-48VDC=						
Allowable voltage range		90 to 110% of rated voltage						
Power consumption	AC voltage	Max. 6VA	Max. 8VA					
	AC/DC voltage	—	Max. 8VA (24VAC 50/60Hz), max. 5W (24-48VDC)					
Display method		7-segment (PV: red, SV: green), other display part (green, yellow, red) LED method						
Character size	PV (W×H)	4.5×7.2mm	7.0×14.0mm	9.5×20.0mm	8.5×17.0mm	7.0×14.6mm	7.0×14.6mm	11.0×22.0mm
	SV (W×H)	3.5×5.8mm	5.0×10.0mm	7.5×15.0mm	6.0×12.0mm	6.0×12.0mm	6.0×12.0mm	7.0×14.0mm
Input type	RTD	JPt100Q, DPt100Q, DPt50Q, Cu100Q, Cu50Q, Nickel 120Q (6 types)						
	Thermocouple	K(CA), J(IC), E(CR), T(CC), B(PR), R(PR), S(PR), N(NN), C(TT), G(TT), L(IC), U(CC), Platinel II (13 types)						
	Analog	• Voltage: 0-100mVDC=, 0-5VDC=, 1-5VDC=, 0-10VDC= (4 types) • Current: 0-20mA, 4-20mA (2 types)						
Display accuracy	RTD	• At room temperature (23°C±5°C): (PV ±0.3% or ±1°C, select the higher one) ±1-digit <sup>※1</sup> • Out of room temperature range: (PV ±0.5% or ±2°C, select the higher one) ±1-digit						
	Thermocouple	※In case of TK4SP Series, ±1°C will be added.						
	Analog	• At room temperature (23°C±5°C): ±0.3% F.S. ±1-digit • Out of range of room temperature: ±0.5% F.S. ±1-digit						
	CT input	±5% F.S. ±1-digit						
Control output	Relay	OUT1, OUT2: 250VAC~ 3A, 30VDC= 3A, 1a						
	SSR	11VDC= ±2V 20mA Max.						
	Current	DC4-20mA or DC0-20mA selectable (load 500Ω max.)						
Alarm output	Relay	AL1, AL2: 250VAC~ 3A 1a ※TK4N AL2: 250VAC~ 0.5A 1a (max.125VA), TK4SP has only AL1.						
	Transmission	DC4-20mA (load 500Ω max., accuracy: ±0.3% F.S.)						
Option output	Communication	RS485 communication output (Modbus RTU)						
	CT input	0.0-50.0A (primary heater current value measuring range) ※CT ratio = 1/1000 (except TK4SP)						
Option input	Digital input	• Contact Input: ON - max. 2kΩ, OFF - min. 90kΩ • Non-contact Input: ON - residual voltage max. 1.0VDC=, OFF - leakage current max. 0.1mA • Outflow current: approx. 0.5mA ※TK4S/M: 1 (TK4S-D□□□ 2, TK4SP: none), TK4N/H/W/L: 2						
	Heating, cooling Heating&cooling	ON/OFF, P, PI, PD, PID control						
Hysteresis		• RTD/Thermocouples: 1 to 100°C/°F (0.1 to 100.0°C/°F) variable • Analog: 1 to 100-digit						
Proportional band (P)		0.1 to 999.9°C/°F (0.1 to 999.9%)						
Integral time (I)		0 to 9999 sec						
Derivative time (D)		0 to 9999 sec						
Control period (T)		• Relay output, SSR drive output: 0.1 to 120.0 sec • Current output or SSR drive output selectable: 1.0 to 120.0 sec						
Manual reset value		0.0 to 100.0%						
Sampling period		50ms						
Dielectric strength		2,000VAC 50/60Hz for 1 min (between power source terminal and input terminal)						
Vibration		0.75mm amplitude at frequency of 5 to 55Hz (for 1 min) in each X, Y, Z direction for 2 hours						
Relay life cycle	Mechanical	• OUT1/2: min. 5,000,000 times • AL1/2: min. 20,000,000 times (TK4H/W/L: min. 5,000,000 times)						
	Electrical	OUT1/OUT2, AL1/AL2: min. 100,000 operations						
Insulation resistance		Over 100MΩ (at 500VDC megger)						
Noise immunity		±2kV R-phase, S-phase the square wave noise (pulse width: 1μs) by the noise simulator						
Memory retention		Approx. 10 years (when using non-volatile semiconductor memory type)						
Environment	Ambient temperature	-10 to 50°C, storage: -20 to 60°C						
	Ambient humidity	35 to 85%RH, storage: 35 to 85%RH						
Protection structure		IP65 (front panel) ※TK4SP: IP50 (front panel)						
Insulation type		Double insulation or reinforced insulation (mark: □, dielectric strength between the measuring input part and the power part: 2kV)						
Approval		CE                                						
Weight <sup>※2</sup>	Approx. 140g	Approx. 130g	Approx. 150g	Approx. 210g	Approx. 211g	Approx. 294g		Approx. 198g
	(approx. 70g)	(approx. 85g)	(approx. 105g)	(approx. 140g)	(approx. 141g)			

※1: ◎ At room temperature (23°C±5°C)

- Thermocouple K, J, T, N, E type, below -100°C/Thermocouple L, U, PLII type, RTD Cu50Q, DPt50Q : (PV ±0.3% or ±2°C, select the higher one) ±1-digit
- Thermocouple C, G, R, S type, below 200°C: (PV ±0.3% or ±3°C, select the higher one) ±1-digit
- Thermocouple B type, below 400°C: there is no accuracy standards.

◎ Out of room temperature range

- RTD Cu50Q, DPt50Q: (PV ±0.5% or ±3°C, select the higher one) ±1-digit
- Thermocouple R, S, B, C, G type: (PV ±0.5% or ±5°C, select the higher one) ±1-digit
- Others, Below -100°C: within ±5°C

In case of TK4SP Series, ±1°C will be added to the degree standard.

※2: The weight includes packaging. The weight in parenthesis is for unit only.

※Environment resistance is rated at no freezing or condensation.

SENSORS

CONTROLLERS

MOTION DEVICES

SOFTWARE

(J) Temperature Controllers

(K) SSRs

(L) Power Controllers

(M) Counters

(N) Timers

(O) Digital Panel Meters

(P) Indicators

(Q) Converters

(R) Digital Display Units

(S) Sensor Controllers

(T) Switching Mode Power Supplies

(U) Recorders

(V) HMIs



(W) Panel PC

(X) Field Network Devices

# TK Series



## ■ Connections

- ※Please check the polarity when connecting temperature sensor or analog input.
- ※Standard model has shaded terminals only.
- ※Operation mode of heating&cooling OUT 2 relay output model is heating or cooling, OUT 2 is available as alarm output 3. (except TK4N Series).
- ※Operation mode of heating&cooling OUT 2 current output model is heating or cooling, OUT 2 is available as transmission output 2.
- ※Use terminals of size specified below.

	a	b
	Min. 3.0mm	Max. 5.8mm
	Min. 3.0mm	Max. 5.8mm

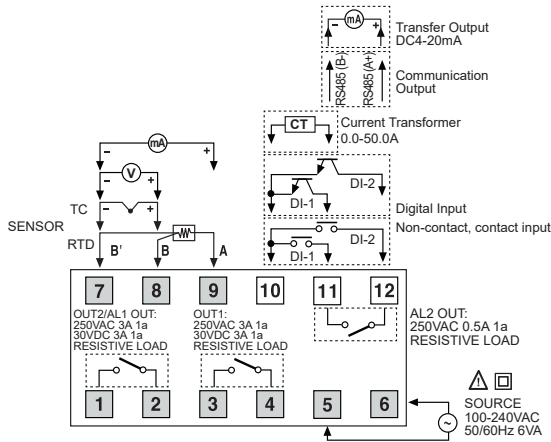
### ● TK4N

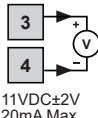
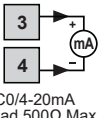
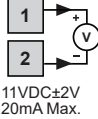

	SSR	Current
OUT1		
	11VDC±2V 20mA Max.	DC0/4-20mA Load 500Ω Max.
OUT2		
	11VDC±2V 20mA Max.	DC0/4-20mA Load 500Ω Max.

### ● TK4S

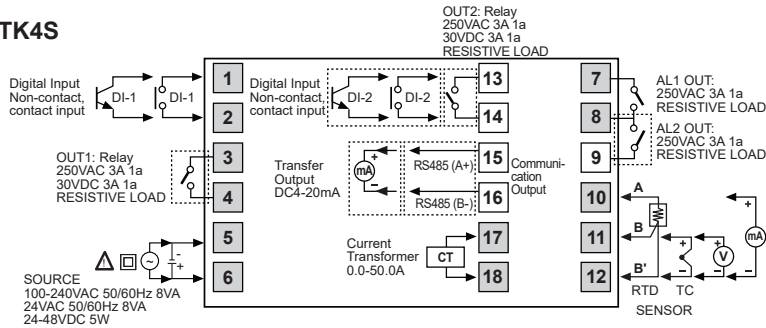

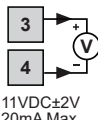
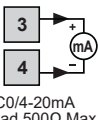
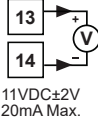
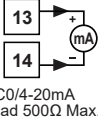
	SSR	Current
OUT1		
	11VDC±2V 20mA Max.	DC0/4-20mA Load 500Ω Max.
OUT2		
	11VDC±2V 20mA Max.	DC0/4-20mA Load 500Ω Max.

### ● TK4SP

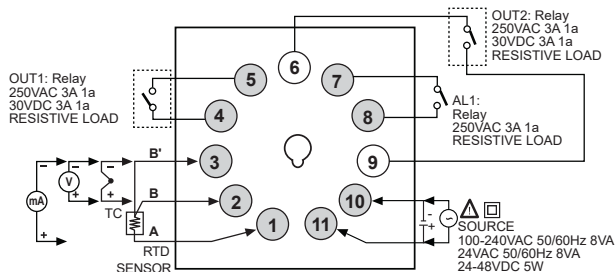

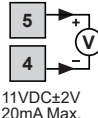
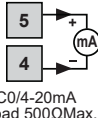
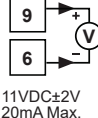
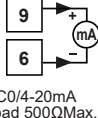
	SSR	Current
OUT1		
	11VDC±2V 20mA Max.	DC0/4-20mA Load 500Ω Max.
OUT2		
	11VDC±2V 20mA Max.	DC0/4-20mA Load 500Ω Max.

# High Performance, General-Purpose, PID Control

## Connections

### TK4M

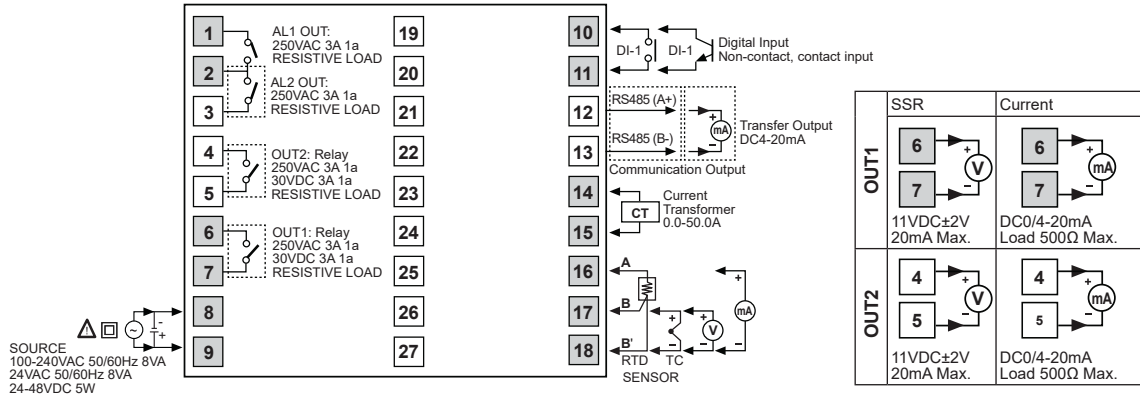

### TK4H/TK4W/TK4L

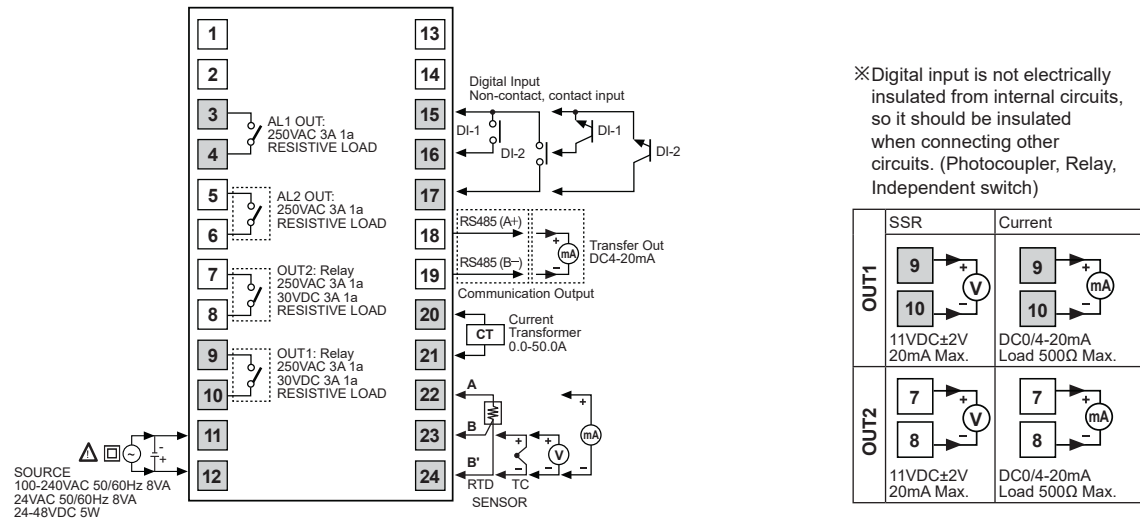

## Dimensions

### TK4N Series

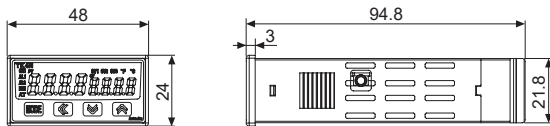

### TK4S Series

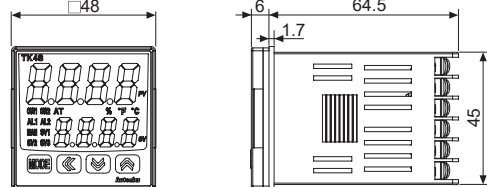

### TK4SP Series

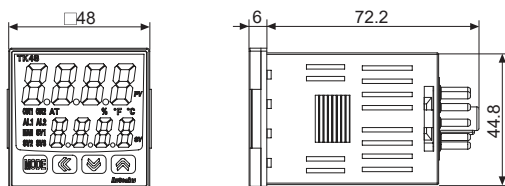

### TK4M Series

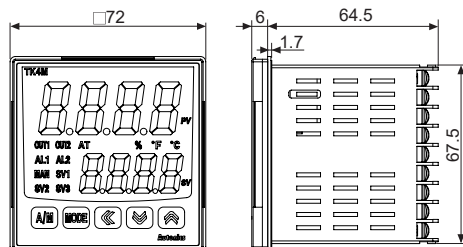

SENSORS

CONTROLLERS

MOTION DEVICES

SOFTWARE

(J) Temperature Controllers

(K) SSRs

(L) Power Controllers

(M) Counters

(N) Timers

(O) Digital Panel Meters

(P) Indicators

(Q) Converters

(R) Digital Display Units

(S) Sensor Controllers

(T) Switching Mode Power Supplies

(U) Recorders

(V) HMIs

(W) Panel PC

(X) Field Network Devices

# TK Series

## ■ Dimensions

(unit: mm)

### ● TK4W Series

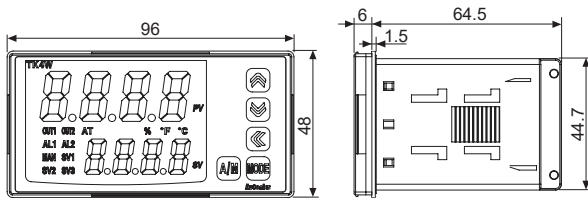

### ● TK4H Series

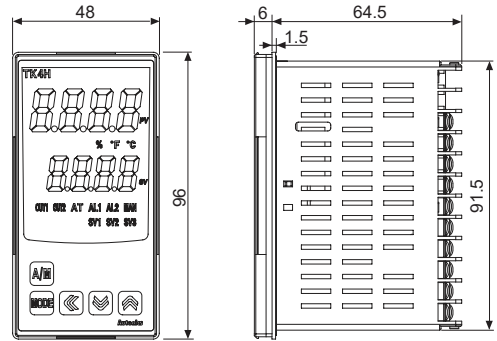

### ● TK4L Series

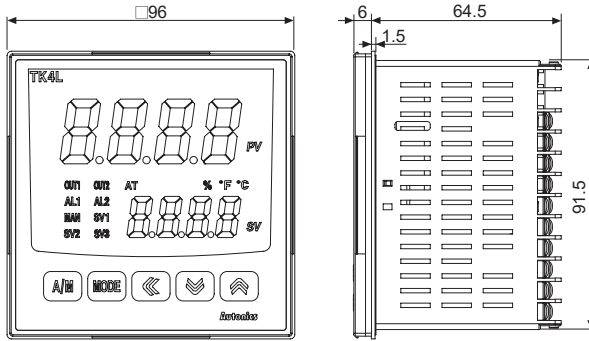

### ● Panel cut-out

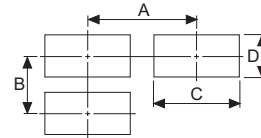

(unit: mm)

Model	Size	A	B	C	D
TK4N		Min. 55	Min. 37	45 <sup>+0.6</sup> <sub>0</sub>	22.2 <sup>+0.3</sup> <sub>0</sub>
TK4S		Min. 65	Min. 65	45 <sup>+0.6</sup> <sub>0</sub>	45 <sup>+0.6</sup> <sub>0</sub>
TK4SP		Min. 65	Min. 65	45 <sup>+0.6</sup> <sub>0</sub>	45 <sup>+0.6</sup> <sub>0</sub>
TK4M		Min. 90	Min. 90	68 <sup>+0.7</sup> <sub>0</sub>	68 <sup>+0.7</sup> <sub>0</sub>
TK4H		Min. 65	Min. 115	45 <sup>+0.6</sup> <sub>0</sub>	92 <sup>+0.8</sup> <sub>0</sub>
TK4W		Min. 115	Min. 65	92 <sup>+0.8</sup> <sub>0</sub>	45 <sup>+0.6</sup> <sub>0</sub>
TK4L		Min. 115	Min. 115	92 <sup>+0.8</sup> <sub>0</sub>	92 <sup>+0.8</sup> <sub>0</sub>

## ● Bracket

### ● TK4N Series

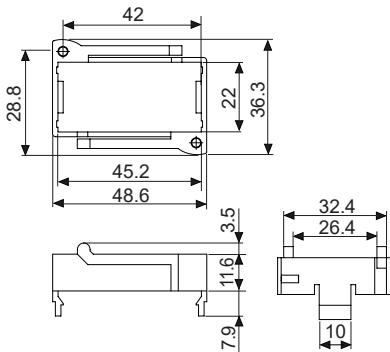

### ● TK4S, TK4SP Series

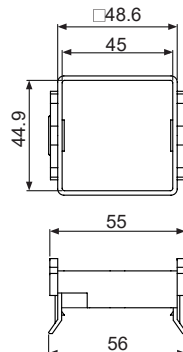

### ● TK4M/W/H/L Series

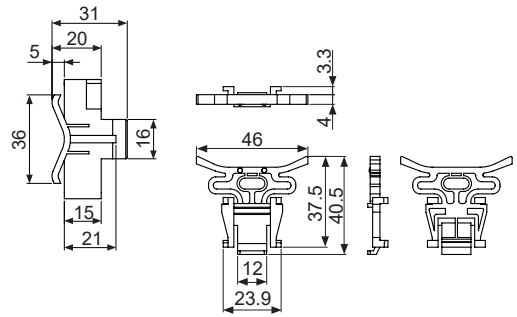

## ● Terminal cover (sold separately)

### ● TK4N Cover (48×24mm)

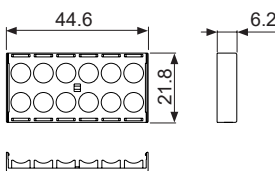

※TK4N COVER is accessory.

### ● RSA Cover (48×48mm)

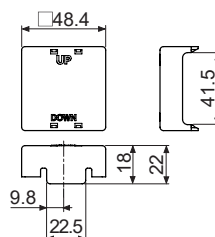

### ● RMA Cover (72×72mm)

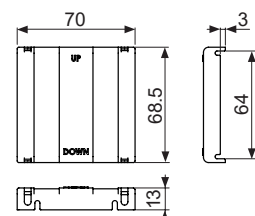

# High Performance, General-Purpose, PID Control

## Dimensions

### Terminal cover (sold separately)

(unit: mm)

#### •RHA Cover (48×96mm, 96×48mm)

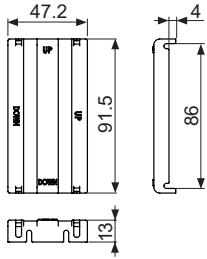

#### •RLA Cover (96×96mm)

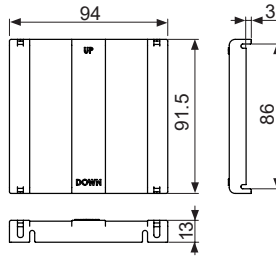

## Product Mounting

### TK4N (48×24mm) Series

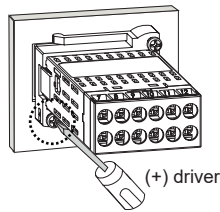

※Insert the unit into a panel, fasten the bolt with a (+) driver.

### TK4S/SP (48×48mm) Series

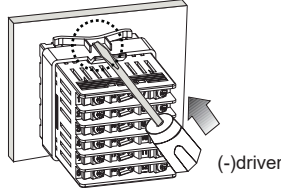

※Insert the unit into a panel, fasten the bracket by pushing with tools with a (-) driver.

### Other Series

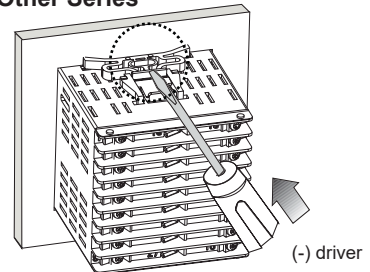

## Unit Description

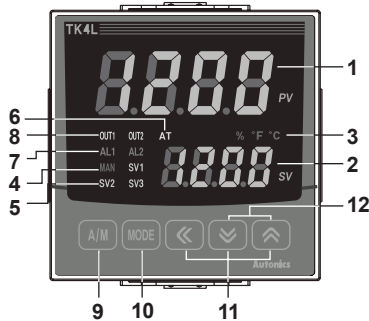

TK4N Series

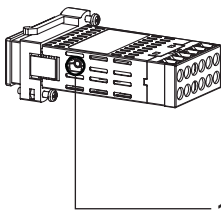

Other Series

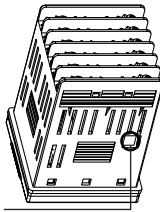

※The input selection switch (TC, RTD/mV, V, mA) switch disappears. Select input type [ n - t ] in parameter 3 group.

### The previous model

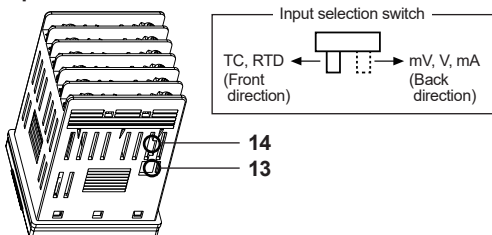

#### 1. Measured value (PV) display part:

- RUN mode: It displays currently measured value (PV).
- Setting mode: It displays the parameter.

#### 2. Set value (SV) display part:

- RUN mode: It displays the set value (SV).
- Setting mode: It displays the set value of the parameter.

#### 3. Unit (°C/°F/%) indicator: It displays the unit set at display unit [U n t] in parameter 3 group. (In case of TK4N, % is not supported)

#### 4. Manual control indicator: It turns ON during manual controlling.

#### 5. Multi SV indicator: One of SV1 to 3 indicators will be ON in case of selecting multi SV function.

#### 6. Auto tuning indicator: It flashes by 1 sec when executing auto tuning.

#### 7. Alarm output (AL 1, AL 2) indicator: It turns ON when the alarm output is ON.

#### 8. Control output (OUT 1, OUT 2) indicator: It turns ON when the control output is ON.

※During cycle/phase controlling in SSRP function model (TK4□ - □4S□) when MV is over 5.0%, it turns ON.

※To use current output, when MV is 0.0% in manual control, it turns OFF. Otherwise, it always turns ON. When MV is over 3.0% in auto control, it turns ON and when MV is below 2.0%, it turns OFF.

#### 9. [A/M] key: It is used when switching auto control to manual control.

※TK4N/S/SP do not have [A/M] key. [MODE] key operates switching simultaneously.

#### 10. [MODE] key: It is used when entering parameter setting group, returning to RUN mode, moving parameter, saving the set value.

#### 11. [Left], [Right], [Up], [Down] key: It is used when entering the set value changing mode and moving or changing up/down digit.

#### 12. Digital input key: When pressing [Left] + [Right] keys for 3 sec at the same time, it operates the function (RUN/STOP, alarm clear, auto tuning) set at digital input key [d i - t] in parameter 5 group.

#### 13. PC loader port: It is the PC loader port for serial communication to set parameter and monitoring by DAQMaster installed in PC. Use this for connecting SCM-US (USB to Serial converter, sold separately).

#### 14. Input selection switch: Used when switching sensor (TC, RTD) input ↔ analog input (mV, V, mA). (only the previous model)

SENSORS
CONTROLLERS
MOTION DEVICES
SOFTWARE

(J) Temperature Controllers
(K) SSRs
(L) Power Controllers
(M) Counters
(N) Timers
(O) Digital Panel Meters
(P) Indicators
(Q) Converters
(R) Digital Display Units
(S) Sensor Controllers
(T) Switching Mode Power Supplies
(U) Recorders
(V) HMIs
(W) Panel PC
(X) Field Network Devices

# TK Series

## ■ Sold Separately

### ◎ Communication converter

#### ● SCM-WF48

(Wi-Fi to RS485-USB wireless communication converter)



#### ● SCM-US481

(USB to RS485 converter)



#### ● SCM-381

(RS232C to RS485 converter)



#### ● SCM-US

(USB to Serial converter)



### ◎ Current transformer (CT)

#### ● CSTC-E80LN

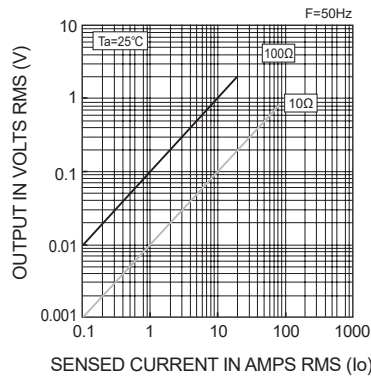
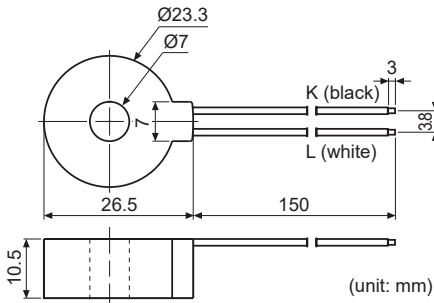

- Max. load current: 80A (50/60Hz)
- ※Max. load current for TK4 Series is 50A.
- Current ratio: 1/1000
- Wire wounded resistance:  $31\Omega \pm 10\%$

#### ● CSTC-E200LN

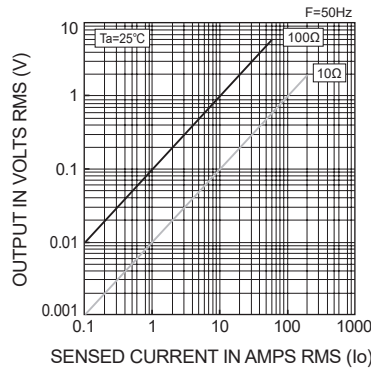
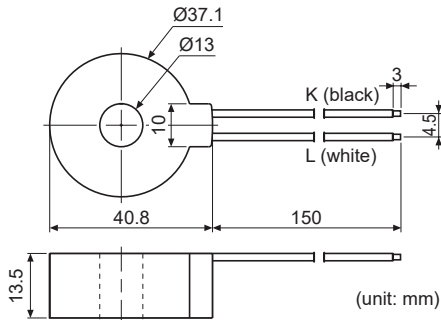

- Max. load current: 200A (50/60Hz)
- ※Max. load current for TK4 Series is 50A.
- Current ratio: 1/1000
- Wire wounded resistance:  $20\Omega \pm 10\%$

#### ● CSTS-E80PP

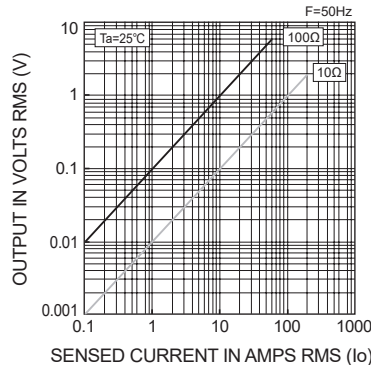
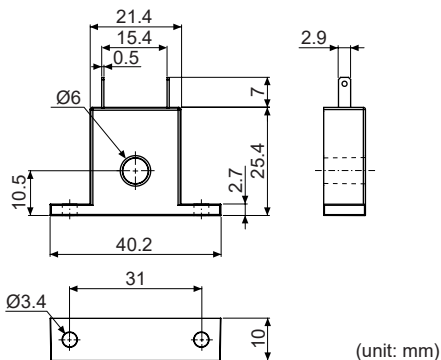

- Max. load current: 80A (50/60Hz)
- ※Max. load current for TK4 Series is 50A.
- Current ratio: 1/1000
- Wire wounded resistance  $31\Omega \pm 10\%$

※Do not supply primary current in case that CT output is open. High voltage will be generated in CT output.

※The current for above CTs is 50A same but inner hole sizes are different. Please use this for your environment.

# High Performance, General-Purpose, PID Control

## ■ Sold Separately

### ◎ Display units (DS/DA-T Series)

- DS/DA-T Series  
(RS485 communication input type display unit) C E



DS16-IT



DS22/DA22-IT



DS40/DA40-IT



DS60/DA60-IT

※Connect RS485 communication input type display unit (DS/DA-T Series) and RS485 communication output model of TK Series, the display unit displays present value of the device without PC/PLC.

## ■ Input Type and Range

Input type		Decimal point	Display	Input range (°C)	Input range (°F)
Thermocouple	K(CA)	1	℄℄℄℄	-200 to 1350	-328 to 2463
		0.1	℄℄℄℄	-199.9 to 999.9	-199.9 to 999.9
	J(IC)	1	℄℄℄℄	-200 to 800	-328 to 1472
		0.1	℄℄℄℄	-199.9 to 800.0	-199.9 to 999.9
	E(CR)	1	℄℄℄℄	-200 to 800	-328 to 1472
		0.1	℄℄℄℄	-199.9 to 800.0	-199.9 to 999.9
	T(CC)	1	℄℄℄℄	-200 to 400	-328 to 752
		0.1	℄℄℄℄	-199.9 to 400.0	-199.9 to 752.0
	B(PR)	1	℄ ℄ ℄	0 to 1800	32 to 3272
	R(PR)	1	℄ ℄ ℄	0 to 1750	32 to 3182
	S(PR)	1	℄ ℄ ℄	0 to 1750	32 to 3182
	N(NN)	1	℄ ℄ ℄	-200 to 1300	-328 to 2372
	C(TT) <sup>※1</sup>	1	℄ ℄ ℄	0 to 2300	32 to 4172
G(TT) <sup>※2</sup>	1	℄ ℄ ℄	0 to 2300	32 to 4172	
L(IC)	1	℄ ℄ ℄ ℄	-200 to 900	-328 to 1652	
	0.1	℄ ℄ ℄ ℄	-199.9 to 900.0	-199.9 to 999.9	
U(CC)	1	℄℄℄℄	-200 to 400	-328 to 752	
	0.1	℄℄℄℄	-199.9 to 400.0	-199.9 to 752.0	
Platinel II	1	℄℄℄℄	0 to 1390	32 to 2534	
RTD	Cu 50Ω	0.1	℄ ℄ ℄	-199.9 to 200.0	-199.9 to 392.0
	Cu 100Ω	0.1	℄ ℄ ℄	-199.9 to 200.0	-199.9 to 392.0
	JPt 100Ω	1	℄ ℄ ℄ ℄	-200 to 650	-328 to 1202
		0.1	℄ ℄ ℄ ℄	-199.9 to 650.0	-199.9 to 999.9
	DPt 50Ω	0.1	℄ ℄ ℄ ℄	-199.9 to 600.0	-199.9 to 999.9
		1	℄ ℄ ℄ ℄	-200 to 650	-328 to 1202
		0.1	℄ ℄ ℄ ℄	-199.9 to 650.0	-199.9 to 999.9
Nickel 120Ω	1	℄ ℄ ℄	-80 to 200	-112 to 392	
Analog	Voltage	0-10V	℄ ℄ ℄	-1999 to 9999 (Display point will be changed according to decimal point position)	
		0-5V	℄ ℄ ℄		
		1-5V	℄ ℄ ℄		
		0-100mV	℄ ℄ ℄ ℄		
	Current	0-20mA	℄ ℄ ℄ ℄		
		4-20mA	℄ ℄ ℄ ℄		

※1: C (TT): Same as existing W5 (TT) type sensor

※2: G (TT): Same as existing W (TT) type sensor

## ■ Front Panel Display When Power Is On

When power is supplied, display will flash for 1 sec. Afterwards, model name and input sensor type will flash twice and then enter into RUN mode.

### 1. Whole display part



### 2. Model type display

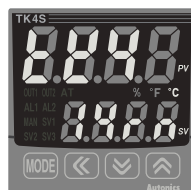

### 3. Input sensor type display



### 4. Run mode



SENSORS
CONTROLLERS
MOTION DEVICES
SOFTWARE
(J) Temperature Controllers
(K) SSRs
(L) Power Controllers
(M) Counters
(N) Timers
(O) Digital Panel Meters
(P) Indicators
(Q) Converters
(R) Digital Display Units
(S) Sensor Controllers
(T) Switching Mode Power Supplies
(U) Recorders
(V) HMIs
(W) Panel PC
(X) Field Network Devices

## Parameter Group

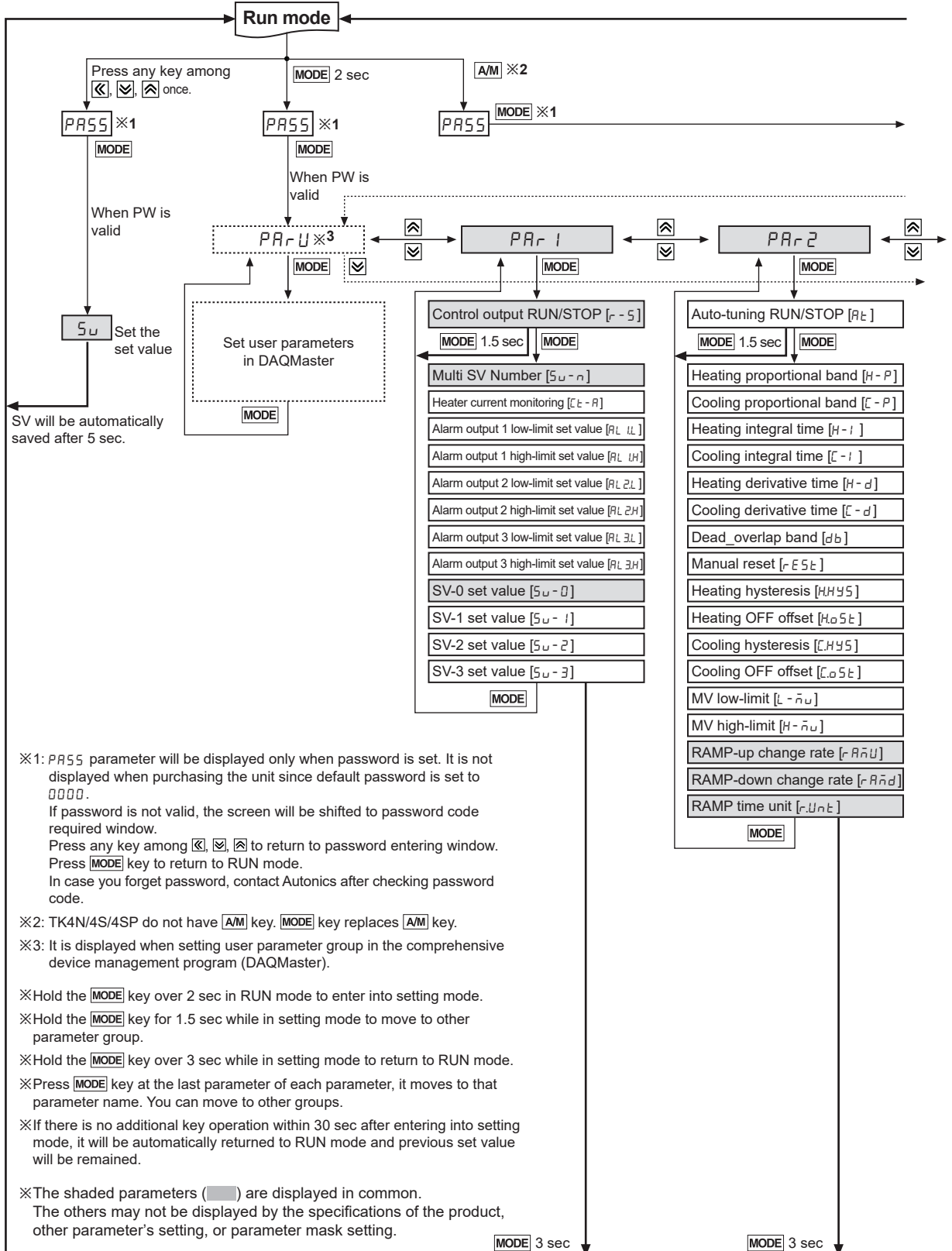

# High Performance, General-Purpose, PID Control

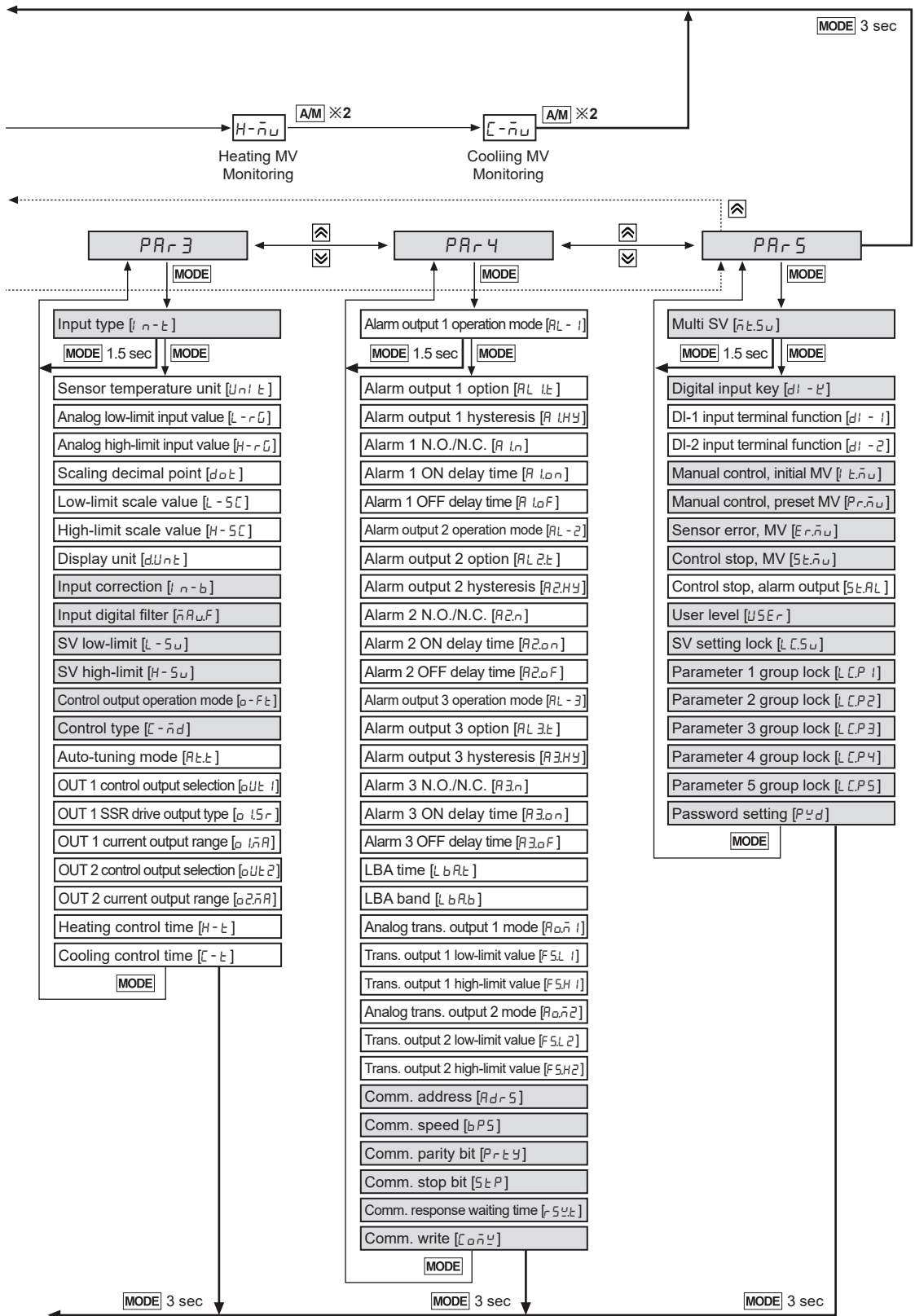

- SENSORS
- CONTROLLERS
- MOTION DEVICES
- SOFTWARE
- (J) Temperature Controllers
- (K) SSRs
- (L) Power Controllers
- (M) Counters
- (N) Timers
- (O) Digital Panel Meters
- (P) Indicators
- (Q) Converters
- (R) Digital Display Units
- (S) Sensor Controllers
- (T) Switching Mode Power Supplies
- (U) Recorders
- (V) HMIs
- (W) Panel PC
- (X) Field Network Devices

## Parameter 1 Group

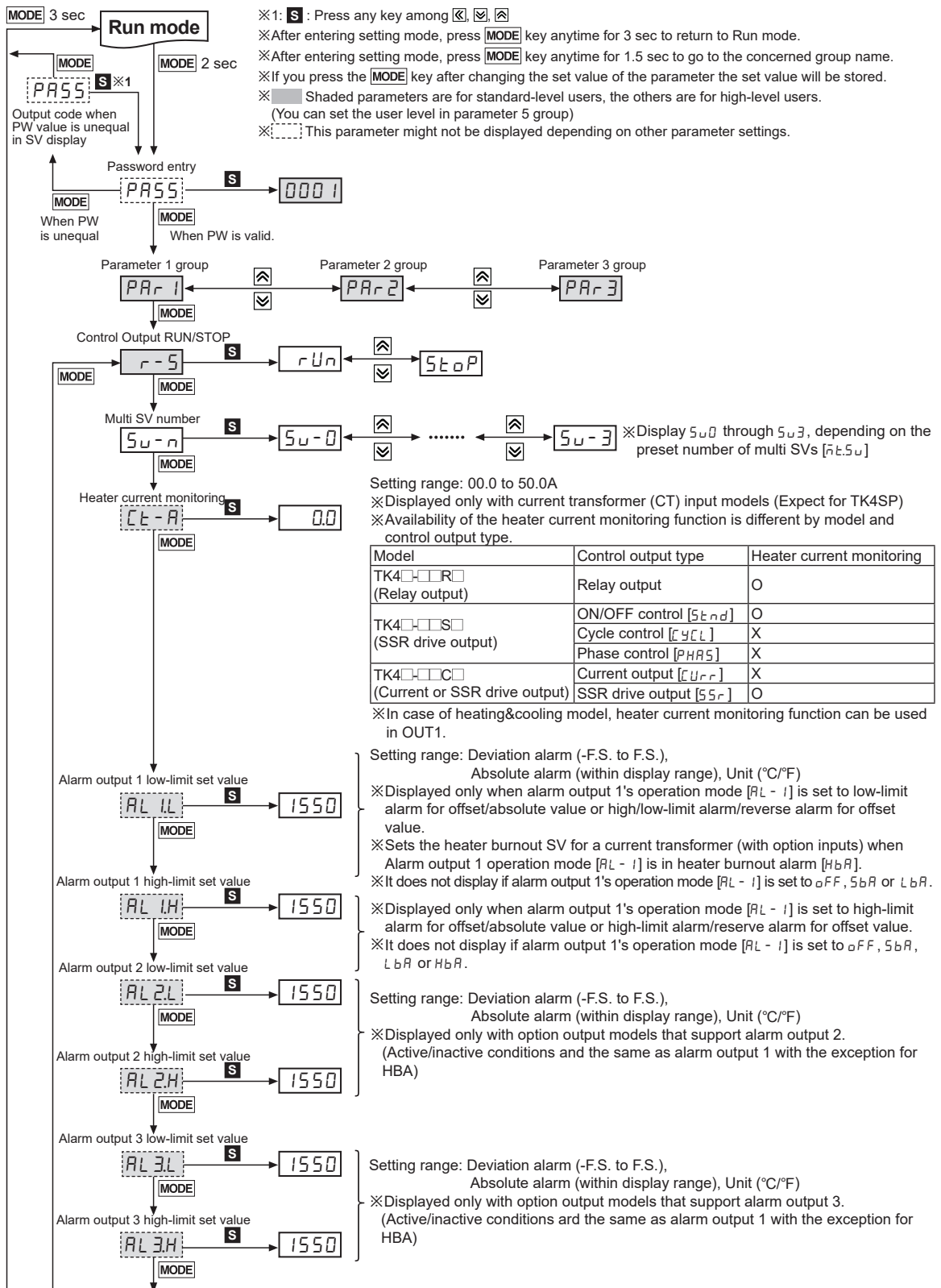

# High Performance, General-Purpose, PID Control

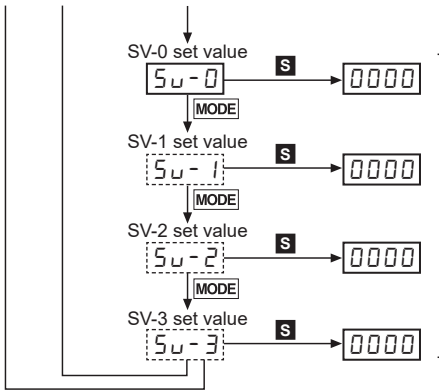

Setting range: L - 5U to H - 5U, unit (°C/°F)  
 ※The number of multi SVs [5U0 to 5U3] set at Multi SV [nL5U] are displayed.

SENSORS
CONTROLLERS
MOTION DEVICES
SOFTWARE

## Parameter 2 Group

- ※1: **S** : Press any key among  $\left[ \leftarrow \right]$ ,  $\left[ \rightarrow \right]$ ,  $\left[ \uparrow \right]$ ,  $\left[ \downarrow \right]$
- ※After entering setting mode, press **MODE** key anytime for 3 sec to return to Run mode.
- ※After entering setting mode, press **MODE** key anytime for 1.5 sec to go to the concerned group name.
- ※If you press the **MODE** key after changing the set value of the parameter the set value will be stored.
- ※ Shaded parameters are for standard-level users, the others are for high-level users.
- (You can set the user level in parameter 5 group)
- ※: [ ] This parameter might not be displayed depending on other parameter settings.

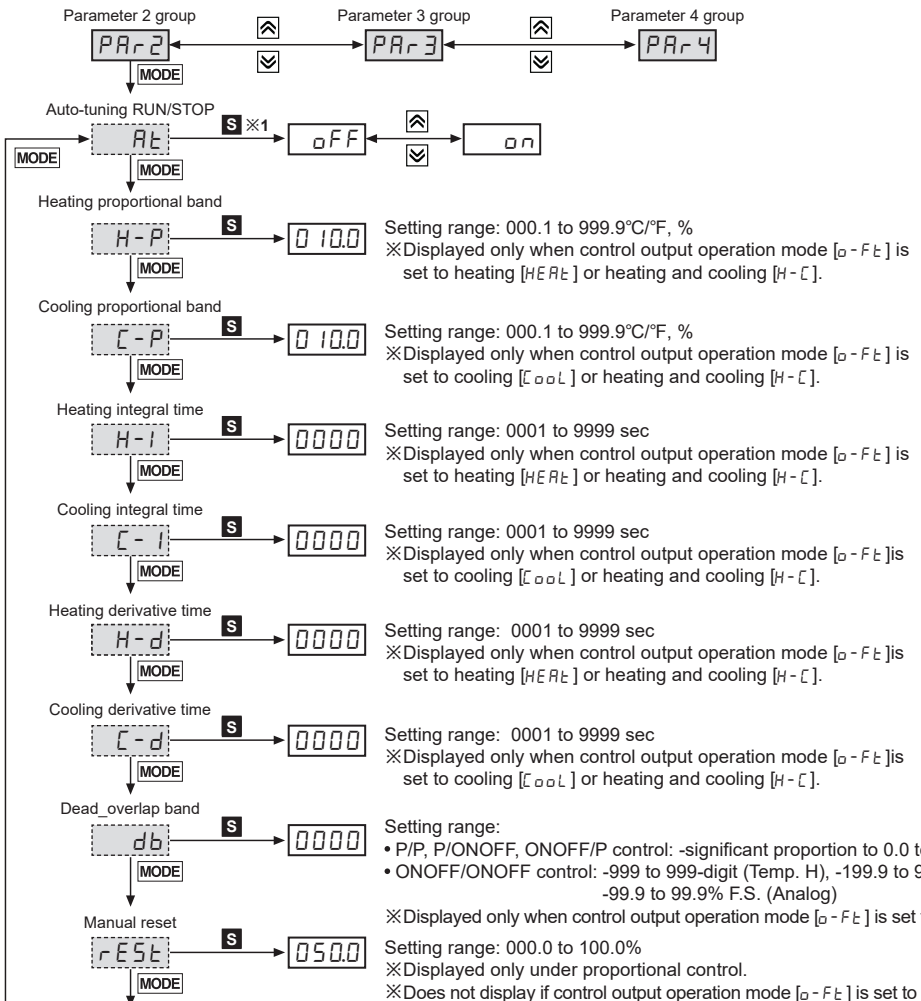

(J) Temperature Controllers

(K) SSRs

(L) Power Controllers

(M) Counters

(N) Timers

(O) Digital Panel Meters

(P) Indicators

(Q) Converters

(R) Digital Display Units

(S) Sensor Controllers

(T) Switching Mode Power Supplies

(U) Recorders

(V) HMIs

(W) Panel PC

(X) Field Network Devices

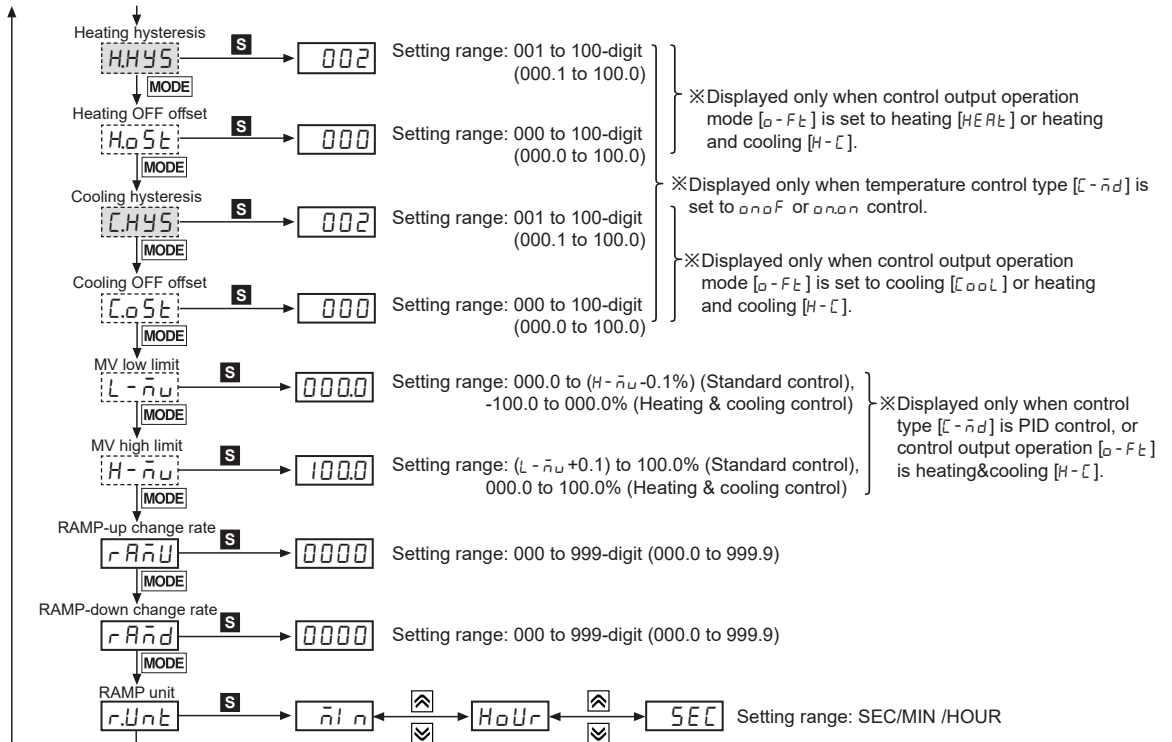

## Parameter 3 Group

- ※1: **S**: Press any key among **◀**, **▶**, **↵**
- ※ After entering setting mode, press **MODE** key anytime for 3 sec to return to Run mode.
- ※ After entering setting mode, press **MODE** key anytime for 1.5 sec to go to the concerned group name.
- ※ If you press the **MODE** key after changing the setting value of the parameter the setting value will be stored.
- ※ Shaded parameters are for standard-level users, the others are for high-level users.
- (You can set the user level in parameter 5 group)
- ※: This parameter might not be displayed depending on other parameter settings.

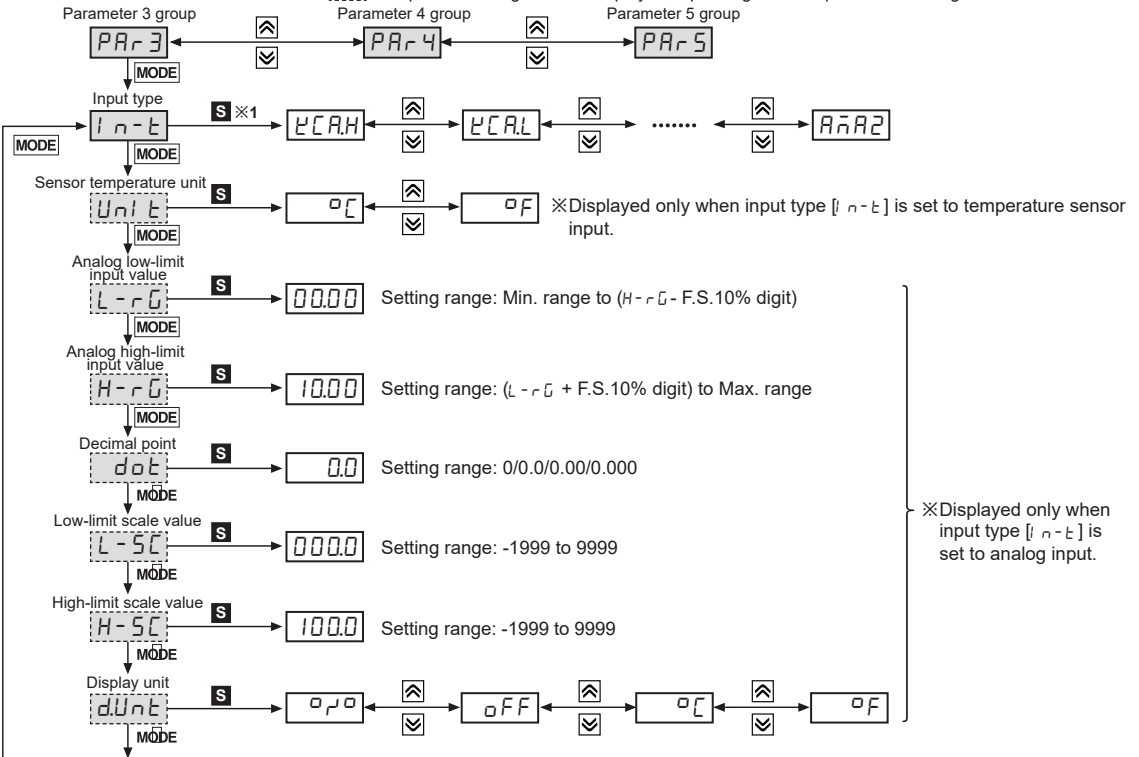

# High Performance, General-Purpose, PID Control

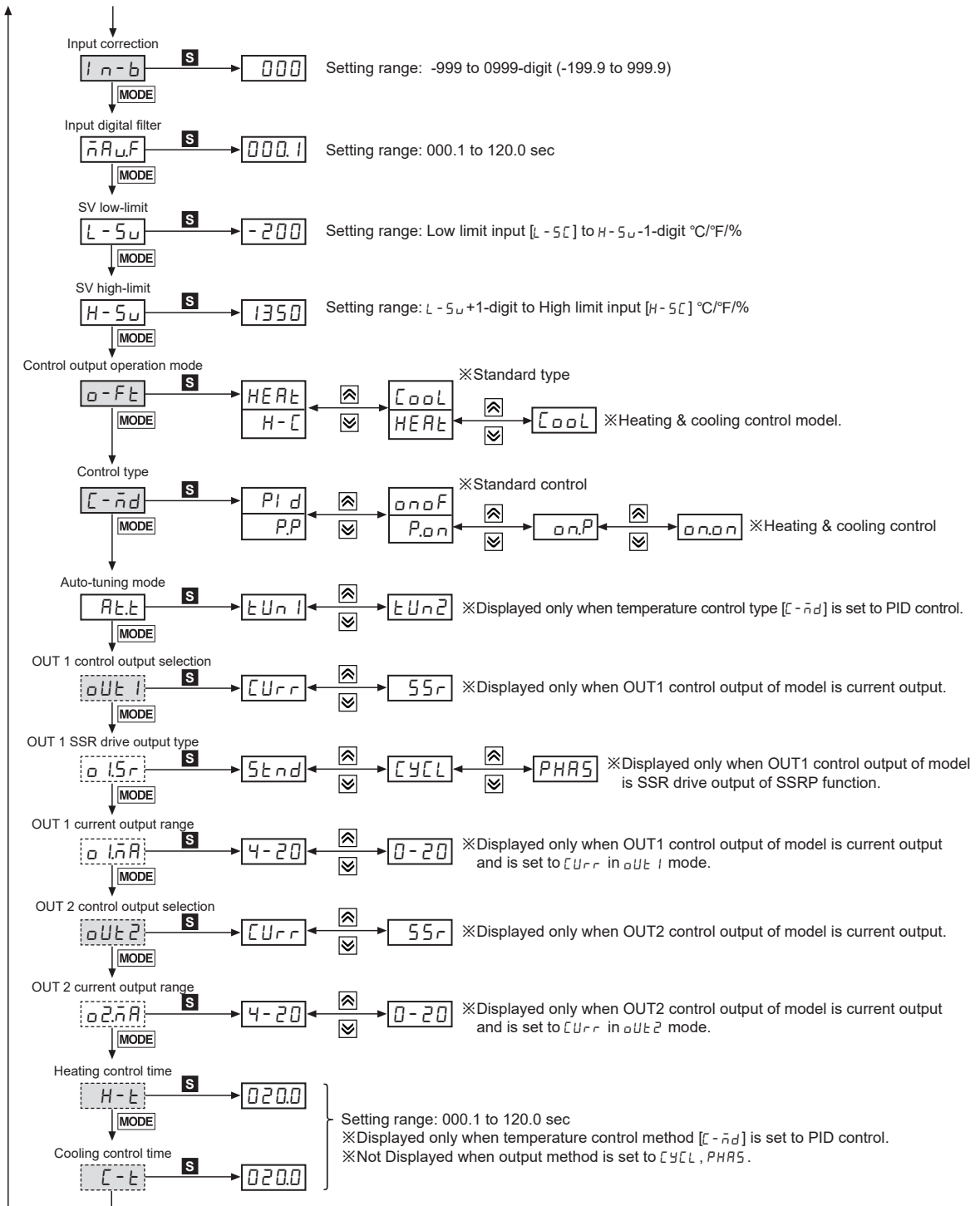





※OUT1, OUT2 output:

- In case that OUT1, OUT2 output is relay output type, oUt1, o1Sr, o1nA, oUt2, o2Sr, o2nA parameter are not displayed.
- In case that OUT1, OUT2 output is current + SSR drive output type, when OUT1, OUT2 output is set to SSR.  
: Output method of o1Sr, o2Sr is held in Stnd and parameter is not displayed.
- In case that OUT1, output is SSR drive output model of SSRP function and OUT2 output is current + SSR drive output  
- oUt1, o1nA are not displayed.  
- o1Sr can set to Stnd, CYCL, PHAS  
- When o2Sr is set to SSR it is held in Stnd and parameter is not displayed.

SENSORS
CONTROLLERS
MOTION DEVICES
SOFTWARE
(J) Temperature Controllers
(K) SSRs
(L) Power Controllers
(M) Counters
(N) Timers
(O) Digital Panel Meters
(P) Indicators
(Q) Converters
(R) Digital Display Units
(S) Sensor Controllers
(T) Switching Mode Power Supplies
(U) Recorders
(V) HMIs
(W) Panel PC
(X) Field Network Devices

## Parameter 4 Group

- ※1: **S** : Press any key among , , 
- ※After entering setting mode, press **MODE** key anytime for 3 sec to return to Run mode.
- ※After entering setting mode, press **MODE** key anytime for 1.5 sec to go to the concerned group name.
- ※If you press the **MODE** key after changing the set value of the parameter the set value will be stored.
- ※  Shaded parameters are for standard-level users, the others are for high-level users.  
(You can set the user level in parameter 5 group)
- ※  This parameter might not be displayed depending on other parameter settings.

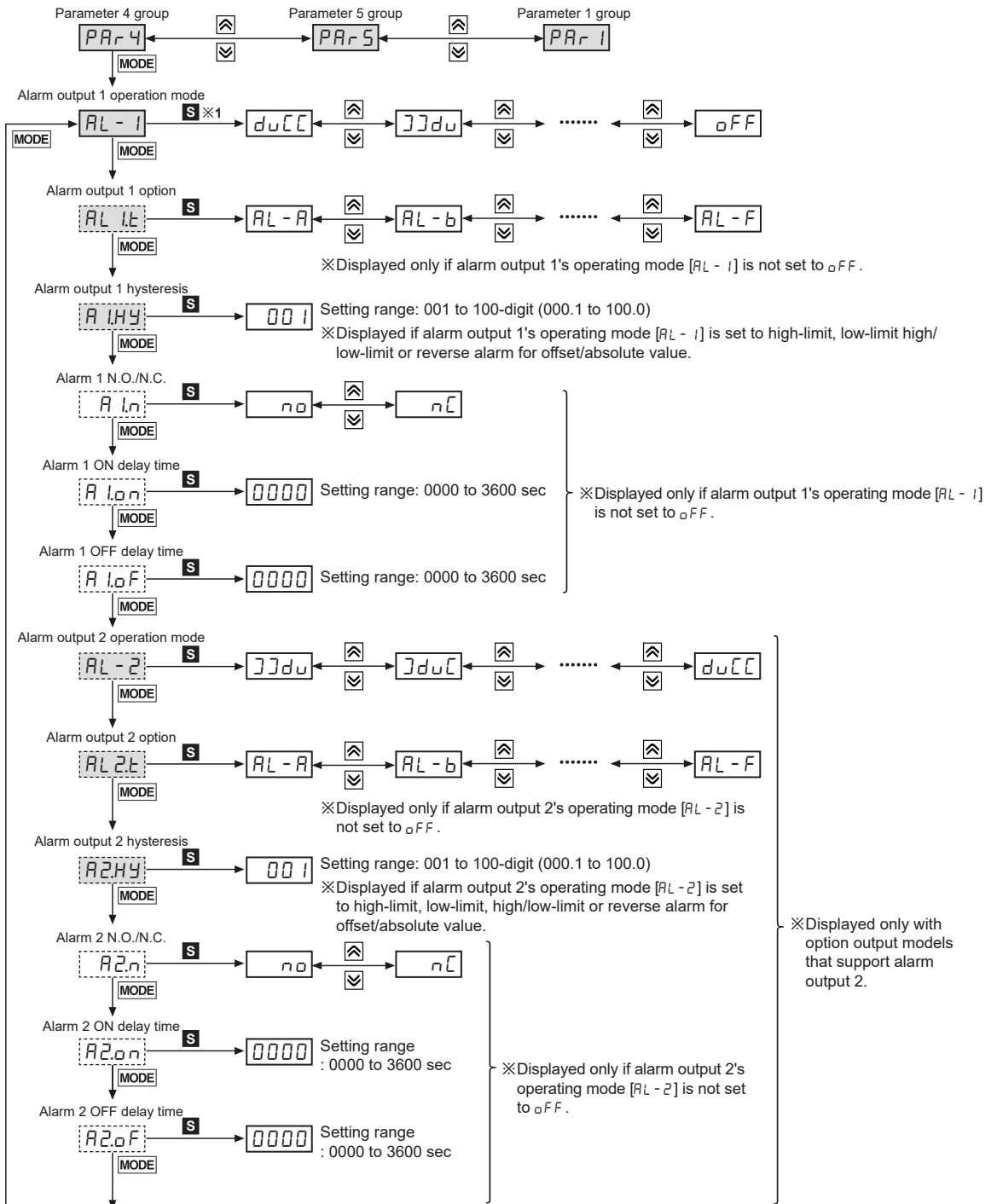

# High Performance, General-Purpose, PID Control

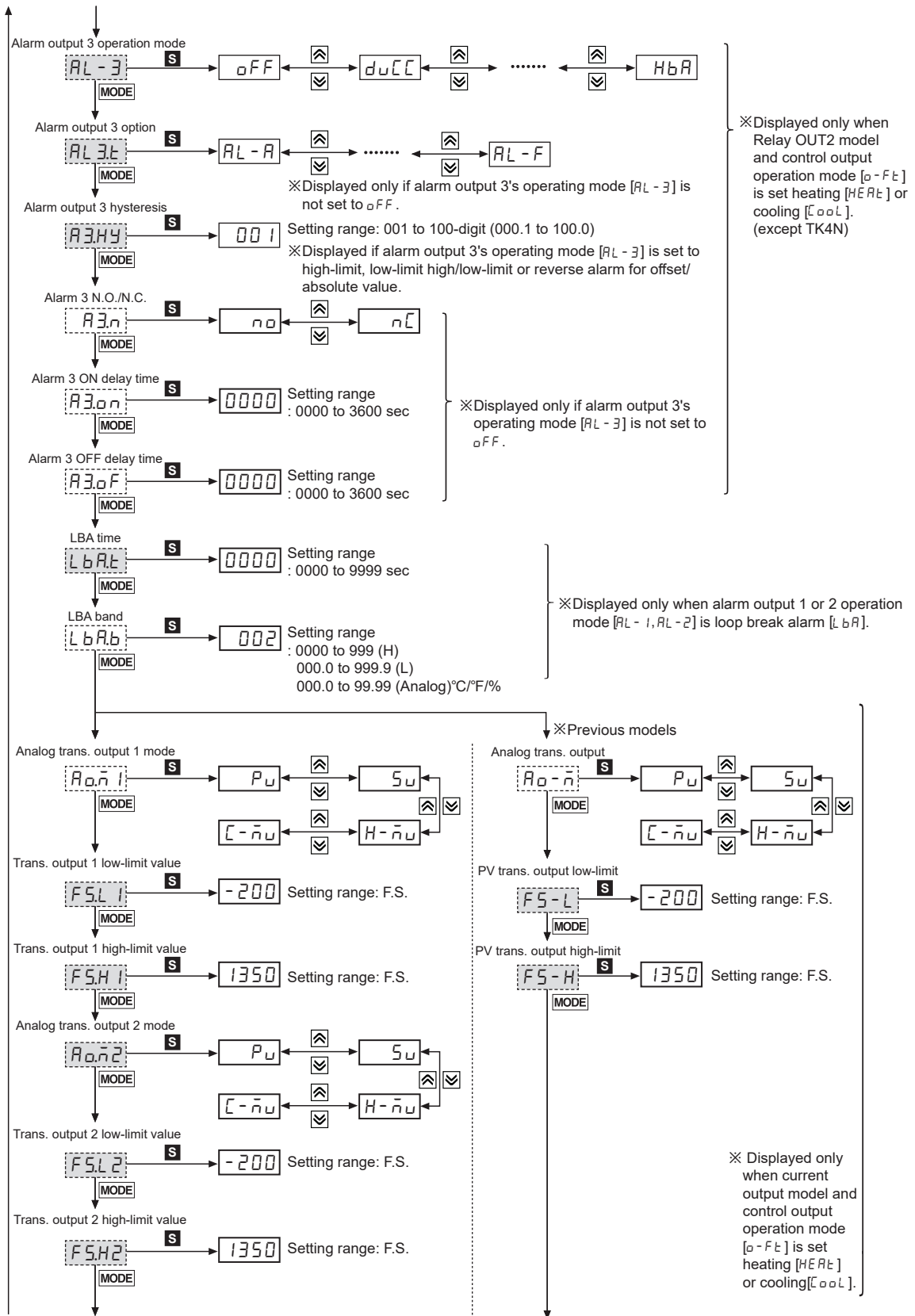

SENSORS
CONTROLLERS
MOTION DEVICES
SOFTWARE
(J) Temperature Controllers
(K) SSRs
(L) Power Controllers
(M) Counters
(N) Timers
(O) Digital Panel Meters
(P) Indicators
(Q) Converters
(R) Digital Display Units
(S) Sensor Controllers
(T) Switching Mode Power Supplies
(U) Recorders
(V) HMIs
(W) Panel PC
(X) Field Network Devices

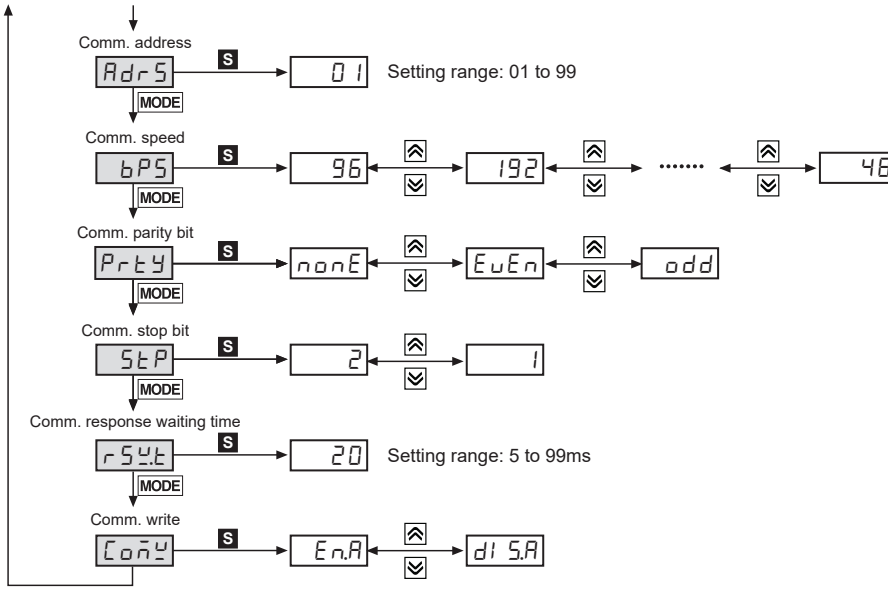

## Parameter 5 Group

- ※1: **S**: Press any key among  $\leftarrow$ ,  $\rightarrow$ ,  $\uparrow$ ,  $\downarrow$ .
- ※After entering setting mode, press **MODE** key anytime for 3 sec to return to Run mode.
- ※After entering setting mode, press **MODE** key anytime for 1.5 sec to go to the concerned group name.
- ※If you press the **MODE** key after changing the setting value of the parameter the setting value will be stored.
- ※ Shaded parameters are for standard-level users, the others are for high-level users.
- (You can set the user level in parameter 5 group)
- ※: This parameter might not be displayed depending on other parameter settings.

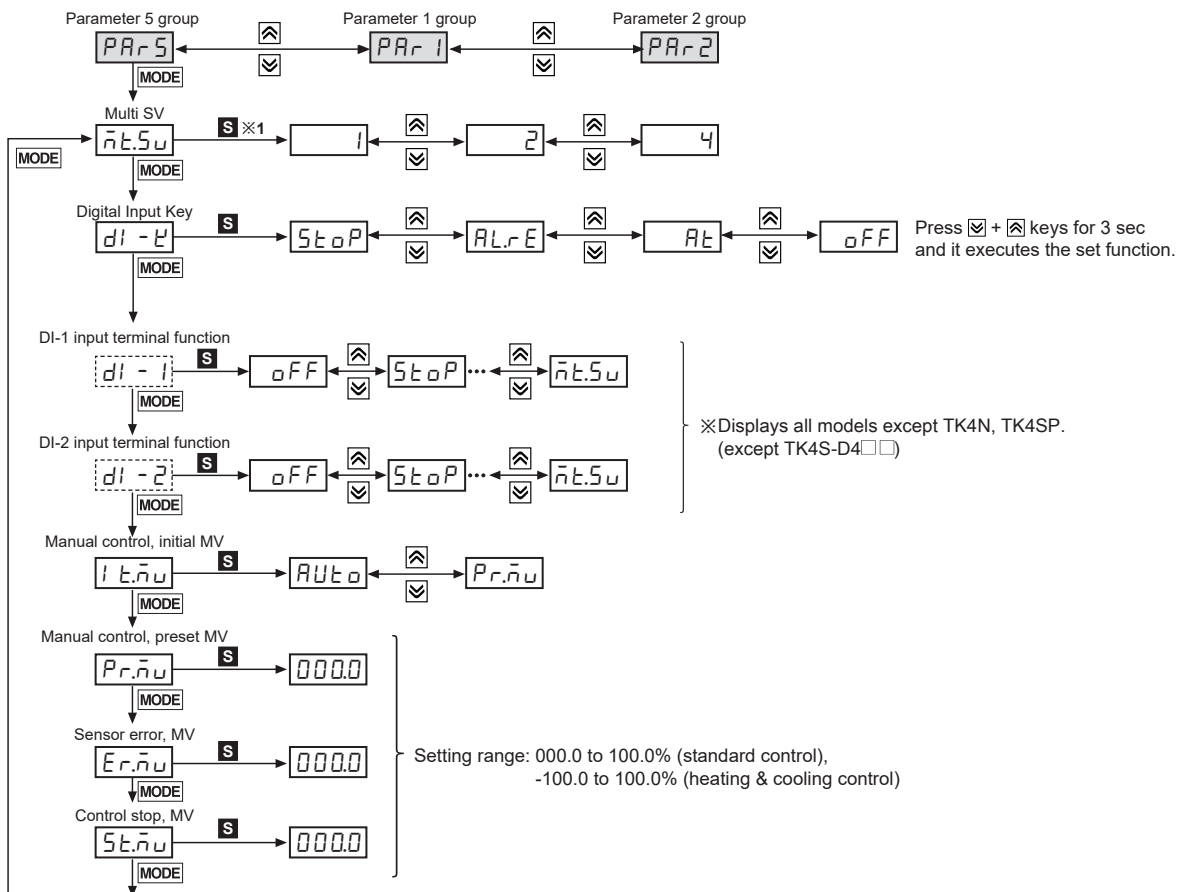

# High Performance, General-Purpose, PID Control

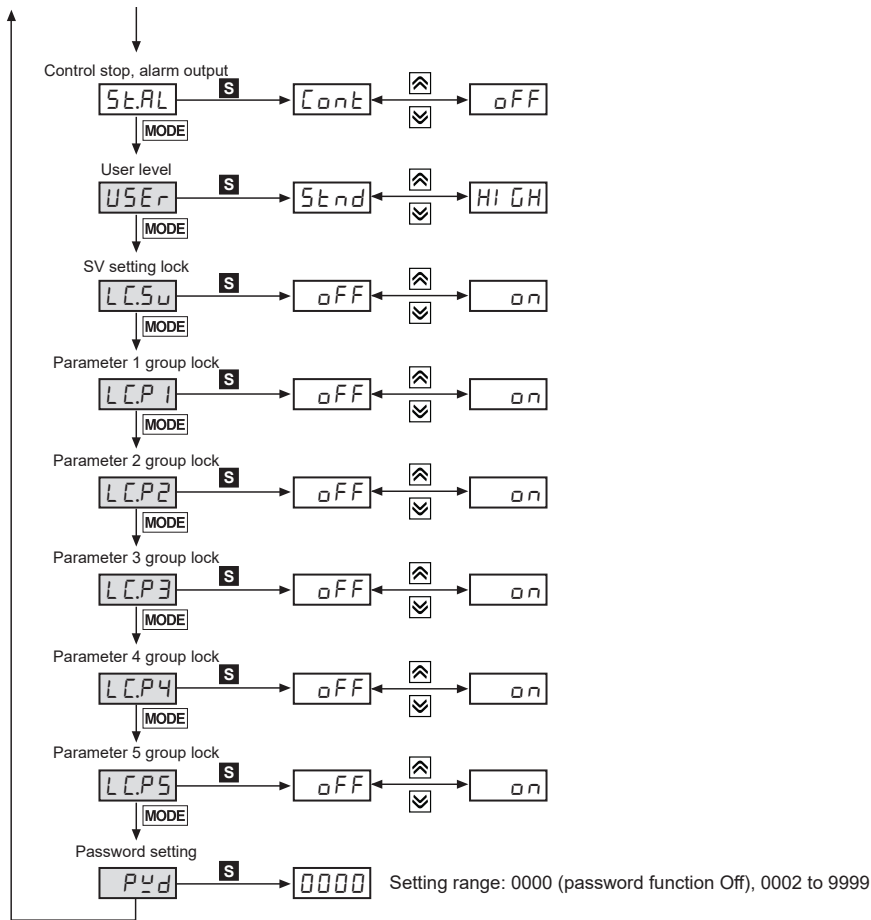

## SV Setting

You can set the temperature to control with  $\leftarrow$ ,  $\rightarrow$ ,  $\uparrow$  keys.  
 Setting range is within SV low-limit value [L - 5u] to SV high-limit value [H - 5u].  
 E.g.) In case of changing set temperature from 210°C to 250°C

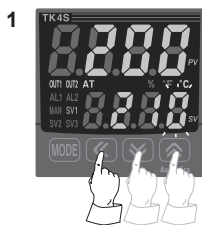

1 Press any key among  $\leftarrow$ ,  $\rightarrow$ ,  $\uparrow$  key in RUN mode, the right digit at SV display flashes and it enters to SV setting.

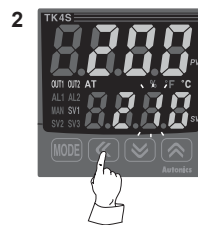

2 Press  $\leftarrow$  key to move the desired digit.  
 ( $10^0 \rightarrow 10^1 \rightarrow 10^2 \rightarrow 10^3 \rightarrow 10^0$ )

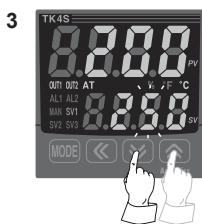

3 Press  $\rightarrow$  or  $\uparrow$  key to move the desired number (1 → 5).

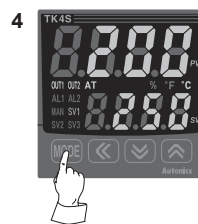

4 Press **MODE** key to save the value and it controls with this set value.  
 (even though there is no key input for over 3 sec, it saves automatically.)

## Parameter Reset

Press  $\leftarrow$ ,  $\rightarrow$ ,  $\uparrow$  to reset all parameters in memory to default value.  
 Set *init* parameter to **YES** to reset all parameters.  
 In case password function is on, it is required to enter valid password to reset parameters.  
 Password is also reset.

SENSORS
CONTROLLERS
MOTION DEVICES
SOFTWARE

(J) Temperature Controllers
(K) SSRs
(L) Power Controllers
(M) Counters
(N) Timers
(O) Digital Panel Meters
(P) Indicators
(Q) Converters
(R) Digital Display Units
(S) Sensor Controllers
(T) Switching Mode Power Supplies
(U) Recorders
(V) HMIs
(W) Panel PC
(X) Field Network Devices

## ■ Factory Default

### ● SV setting [Sv]

Parameter	Factory default
Sv	0

### ● Password input parameter

Parameter	Factory default
PASS	0001

### ● Parameter 1 group [PAR-1]

Parameter	Factory default	Parameter	Factory default	Parameter	Factory default	Parameter	Factory default
r-S	rUn	AL1H	1550	AL3H	1550	Sv-3	0000
Sv-n	Sv-0	AL2L	1550	Sv-0	0000	/	
Ct-A	00	AL2H	1550	Sv-1	0000		
AL1L	1550	AL3L	1550	Sv-2	0000		

### ● Parameter 2 group [PAR-2]

Parameter	Factory default	Parameter	Factory default	Parameter	Factory default	Parameter	Factory default
AL	oFF	H-d	0000	HoSE	000	rAnU	000
H-P	0100	C-d	0000	CHYS	002	rAnd	000
C-P	0100	db	0000	CoSE	000	rUnt	nIn
H-1	0000	rESE	0500	L-nu	+1000	/	
C-1	0000	HHYS	002	H-nu	1000		

### ● Parameter 3 group [PAR-3]

Parameter	Factory default	Parameter	Factory default	Parameter	Factory default	Parameter	Factory default
In-t	ECRH	H-SC	1000	o-Ft	HEAL (standard)	o15r	5tnd
Un-t	oC	dUnt	oPo		H-C (heating & cooling)	o1nA	4-20
L-rG	0000	In-b	0000	C-n-d	Pl-d (standard)	oUt2	CUrr
H-rG	1000	nAuF	000.1		P.P (heating & cooling)	o2nA	4-20
dot	00	L-Sv	-200	ALt	tUn1	H-t	0200 (relay)
L-SC	0000	H-Sv	1350	oUt1	CUrr	C-t	0020 (SSR)

### ● Parameter 4 group [PAR-4]

Parameter	Factory default	Parameter	Factory default	Parameter	Factory default	Parameter	Factory default
AL-1	dUCC	A2n	no	LbAL	0000	bPS	96
AL1t	AL-A	A2on	0000	LbAb	002 (003 <sup>*1</sup> )	PrtY	nonE
ALHY	001	A2oF	0000	Ro-n1 (Ro-n <sup>*1</sup> )	Pu	5tP	2
ALn	no	AL-3	oFF	FSL1 (FS-L <sup>*1</sup> )	-200	r5yt	20
ALon	0000	AL3t	AL-A	F5H1 (FS-H <sup>*1</sup> )	1350	Co-nY	EnA
ALoF	0000	A3HY	001	Ro-n2	Pu	/	
AL-2	JJdw	A3n	no	F5L2	-200		
AL2t	AL-A	A3on	0000	F5H2	1350		
A2HY	001	A3oF	0000	Adr5	01		

### ● Parameter 5 group [PAR-5]

Parameter	Factory default	Parameter	Factory default	Parameter	Factory default	Parameter	Factory default
n-tSv	1	Pr-nu	0000	LCSv	oFF	LCP5	oFF
dl-t	5toP	Er-nu	0000	LCP1	oFF	/	
dl-1	oFF	5t-nu	0000	LCP2	oFF		
dl-2	oFF	5tAL	Cont	LCP3	oFF		
lt-nu	AUto	USEr	5tnd	LCP4	oFF		

※ Shaded parameters are only for the new model.

※1: This parameter is for previous models.

# High Performance, General-Purpose, PID Control

## Alarm

### Alarm operation

Mode	Name	Alarm operation	Description
OFF	—	—	No alarm output
$d_{uL}$	Deviation high-limit alarm	<p>High deviation: Set as 10°C      High deviation: Set as -10°C</p>	If deviation between PV and SV as high-limit is higher than set value of deviation temperature, the alarm output will be ON.
$]]d_u$	Deviation low-limit alarm	<p>Lower deviation: Set as 10°C      Lower deviation: Set as -10°C</p>	If deviation between PV and SV as low-limit is higher than set value of deviation temperature, the alarm output will be ON.
$]]d_uL$	Deviation high/low-limit alarm	<p>Lower deviation: Set as 10°C, High deviation: Set as 20°C</p>	If deviation between PV and SV as high/low-limit is higher than set value of deviation temperature, the alarm output will be ON.
$[d_u]$	Deviation high/low-limit reserve alarm	<p>Lower deviation: Set as 10°C, High deviation: Set as 20°C</p>	If deviation between PV and SV as high/low-limit is higher than set value of deviation temperature, the alarm output will be OFF.
$P_{uL}$	Absolute value high limit alarm	<p>Absolute-value Alarm: Set as 90°C      Absolute-value Alarm: Set as 110°C</p>	If PV is higher than the absolute value, the output will be ON.
$]]P_u$	Absolute value low limit alarm	<p>Absolute-value Alarm: Set as 90°C      Absolute-value Alarm: Set as 110°C</p>	If PV is lower than the absolute value, the output will be ON.
$LbA$	Loop break Alarm	—	It will be ON when it detects loop break.
$SbA$	Sensor break Alarm	—	It will be ON when it detects sensor disconnection.
$HbA$	Heater break alarm	—	It will be ON when CT detects heater break.

※H: Alarm  output hysteresis [ $A_{HY}$ ]

※Availability of the heater burnout alarm function is different by model and control output type.

Model	Control output type	Heater burnout alarm
TK4□□□R□ (Relay output)	Relay output	O
TK4□□□S□ (SSR drive output)	ON/OFF control [ $Stnd$ ]	O
	Cycle control [ $yCL$ ]	X
	Phase control [ $PHS$ ]	X
TK4□□□□□ (Current or SSR drive output)	Current output [ $Urr$ ]	X
	SSR drive output [ $Sr$ ]	O

※In case of heating&cooling model, heater burnout alarm function can be used in OUT1.

### Alarm option

Mode	Name	Description
$AL - A$	Standard alarm	If it is an alarm condition, alarm output is ON. If it is a clear alarm condition, alarm output is OFF.
$AL - b$	Alarm latch	If it is an alarm condition, alarm output is ON and maintains ON status.
$AL - C$	Standby sequence 1	First alarm condition is ignored and from second alarm condition, standard alarm operates. When power is supplied and it is an alarm condition, this first alarm condition is ignored and from the second alarm condition, standard alarm operates.
$AL - d$	Alarm latch and standby sequence 1	If it is an alarm condition, it operates both alarm latch and standby sequence. When power is supplied and it is an alarm condition, this first alarm condition is ignored and from the second alarm condition, alarm latch operates.
$AL - E$	Standby sequence 2	First alarm condition is ignored and from second alarm condition, standard alarm operates. When re-applied standby sequence and if it is alarm condition, alarm output does not turn ON. After clearing alarm condition, standard alarm operates.
$AL - F$	Alarm latch and standby sequence 2	Basic operation is same as alarm latch and standby sequence 1. It operates not only by power ON/OFF, but also alarm set value, or alarm option changing. When re-applied standby sequence and if it is alarm condition, alarm output does not turn ON. After clearing alarm condition, alarm latch operates.

※Condition of re-applied standby sequence for standby sequence 1, alarm latch and standby sequence 1: Power ON  
 Condition of re-applied standby sequence for standby sequence 2, alarm latch and standby sequence 2: Power ON, changing set temperature, alarm temperature [ $AL_1, AL_2$ ] or alarm operation [ $AL - 1, AL - 2$ ], switching STOP mode to RUN mode.

SENSORS

CONTROLLERS

MOTION DEVICES

SOFTWARE

(J) Temperature Controllers

(K) SSRs

(L) Power Controllers

(M) Counters

(N) Timers

(O) Digital Panel Meters

(P) Indicators

(Q) Converters

(R) Digital Display Units

(S) Sensor Controllers

(T) Switching Mode Power Supplies

(U) Recorders

(V) HMIs

(W) Panel PC

(X) Field Network Devices

## ■ Functions

### ⊙ Parameter mask

- This function is able to hide unnecessary parameters to user environment or less frequently used parameters in parameter setting group. You can set this in the comprehensive device management program (DAQMaster).
- Though masked parameters are not displayed in parameter setting group, the parameter set values are applied. For more information, refer to the DAQMaster user manual.
- Visit our web site ([www.autonics.com](http://www.autonics.com)) to download the DAQMaster program and the user manual.

※E.g.)The above is masking auto tuning [A<sub>t</sub>], cooling proportional band [C-P], cooling integral time [C-I], cooling derivative time [C-d] parameters in parameter 2 group.

Before applying mask PAr2 → A<sub>t</sub> → H-P → C-P → H-I → C-I → H-d → C-d...

After applying mask PAr2 → H-P → H-I → H-d...

※This function is for new model.

### ⊙ User parameter group [PArU] setting

- This function is able to set the frequently used parameters to the user parameter group. You can quickly and easily set parameter settings.
- User parameter group can have up to 30 parameters in the comprehensive device management program (DAQMaster). For more information, refer to the DAQMaster user manual.
- Visit our website ([www.autonics.com](http://www.autonics.com)) to download the DAQMaster program and the user manual.

※E.g.)The above is setting user parameter group in the DAQMaster with alarm output 1 low-limit value [AL LL], alarm output 1 high-limit value [AL LH], SV-0 set value [SV-0] parameter of parameter 1 group, heating hysteresis [HHYS], cooling hysteresis [CHYS] parameters of parameter 2 group, input correction [I n-b] parameter of parameter 3 group, alarm output 1 hysteresis [A1HY], alarm output 2 hysteresis [A2HY] parameters of parameter 4 group.

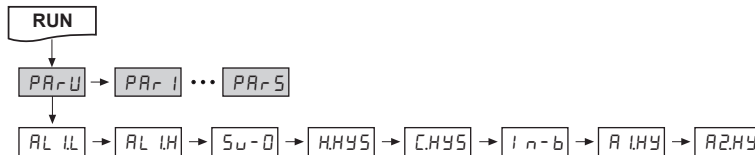

※This function is for new model.

### ⊙ Auto tuning [A<sub>t</sub>]

In PID control, auto-tuning determines the control subject's thermal characteristics and thermal response rate, and then determines the necessary PID time constant. Application of the PID time constant realizes fast response and high precision temperature control.

- Auto-tuning automatically stores PID time constants upon termination. These PID time constants can then be modified by the user to suit their usage environment.
- When auto-tuning is in progress, the AT indicator located on the front of the controller flashes in 1 second intervals. When auto-tuning finishes, the AT indicator automatically goes off and the auto-tuning parameter will return to OFF.

Set value	Descriptions
0FF	Auto tuning end
0n	Auto tuning run

Setting group	Parameter	Setting range	Factory default	Unit
PAr2	A <sub>t</sub>	0FF / 0n	0FF	—

※Manual interruption or a sensor disconnection error when auto-tuning is in progress restores the PID time constant to the value used prior to the auto-tuning session.

※Auto-tuning continues to run even if the temperature reading exceeds or falls below the input range.

※When auto-tuning is in progress, parameters can only be referenced and not altered.

※Auto-tuning is not available in manual control.

# High Performance, General-Purpose, PID Control

## ◎ Control output operation mode [o-Ft]

- Control output modes for general temperature control include heating, cooling, and heating and cooling.
- Heating control and cooling control are mutually opposing operations with inverse outputs.
- The PID time constant varies based on the controlled objects during PID control.

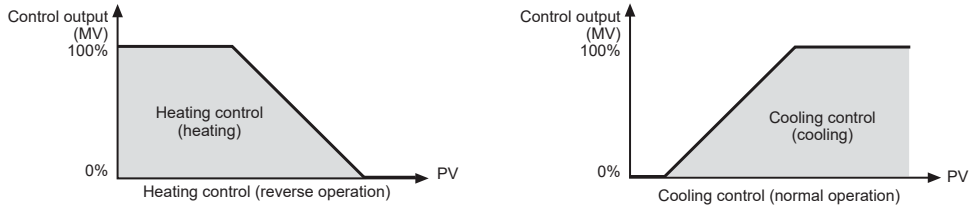

Setting group	Parameter	Setting range	Factory default	Unit
PRr3	o-Ft	Standard model HEAt / CoOL	HEAt	—
		Heating & Cooling model HEAt / CoOL / H-C	H-C	—

### ● Heating control [HEAt]

Heating control mode: the output will be provided in order to supply power to the load (heater) if PV (Present Value) falls below SV (Set value).

### ● Cooling control [CoOL]

Cooling control mode: the output will be provided in order to supply power to the load (cooler) if PV (Present Value) rises above SV (Set value).

### ● Heating and cooling control [H-C]

Heating and cooling control mode: heating and cooling with a single temperature controller when it is difficult to control subject temperature with only heating or cooling.

Heating and cooling control mode controls the object using different PID time constants for each heating and cooling.

It is also possible to set heating and cooling control in both PID control or ON/OFF control mode.

Heating/cooling output can be selected among Relay output, SSR drive output and current output depending on model types chosen according to your application environment.

(Note that only standard SSR control is available for SSR drive output in OUT2.)

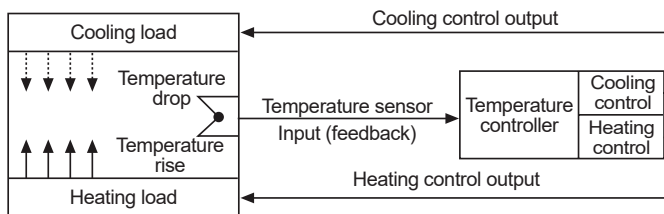

※For heating and cooling control, OUT1 control output is dedicated to heating control and OUT2 control output to cooling control.

## ◎ Control output (OUT1/OUT2) selection [oUt1 // oUt2]

- In case of selecting the Models with current control output, both current and SSR drive outputs are available. You can therefore choose the right output type depending on application environments.
  - OUT1: Selects OUT1 control output.
  - OUT2: Selects OUT2 control output.

Setting group	Parameter	Setting range	Factory default	Unit
PRr3	oUt1	SSr / CoOL	SSr	—
	oUt2			

SENSORS
CONTROLLERS
MOTION DEVICES
SOFTWARE
(J) Temperature Controllers
(K) SSRs
(L) Power Controllers
(M) Counters
(N) Timers
(O) Digital Panel Meters
(P) Indicators
(Q) Converters
(R) Digital Display Units
(S) Sensor Controllers
(T) Switching Mode Power Supplies
(U) Recorders
(V) HMIs
(W) Panel PC
(X) Field Network Devices

## ◎ Communication output

It is for parameter setting and monitoring via external devices (PC, PLC, etc.).

### • Interface

Comm. protocol	Modbus RTU	Comm. speed	2400, 4800, 9600, 19200, 38400 bps
Connection type	RS485	Comm. response wait time	5 to 99 ms
Application standard	Compliance with EIA RS485	Start bit	1-bit (fixed)
Max. connection	31 units (address: 01 to 99)	Data bit	8-bit (fixed)
Synchronous method	Asynchronous	Parity bit	None, Odd, Even
Comm. method	Two-wire half duplex	Stop bit	1-bit, 2-bit
Comm. distance	Max. 800m		

※It is not allowed to set overlapping communication address at the same communication line.

Use twisted pair wire for RS485 communication.

### • Application of system organization

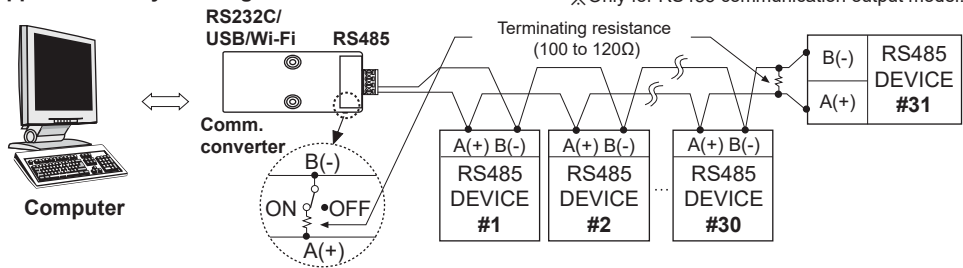

※It is recommended to use Autonics communication converter; SCM-WF48 (Wi-Fi to RS485:USB wireless communication converter, sold separately), SCM-US48I (USB to RS485 converter, sold separately), SCM-38I (RS232C to RS485 converter, sold separately), SCM-US (USB to Serial converter, sold separately).

Please use twisted pair wire, which is suitable for RS485 communication, for SCM-WF48, SCM-US48I and SCM-38I.

## ◎ For more information, refer to the user manual.

## ■ Proper Usage

### ◎ Simple "Error" diagnosis

#### • When the load (heater etc) is not operated

Please check operation of the OUT indicator located in front panel of the unit.

If the OUT indicator does not operate, please check the parameter of all programmed mode.

If OUT indicator is operating, please check the output (Relay, SSR drive voltage) after separating output line from the unit.

#### • When it displays $\square PE n$ during operation

This is a warning that external sensor is open. Please turn off the power and check the wire state of the sensor. If sensor is not open disconnect sensor line from the unit and short the input +, - terminal. Turn on the power of the unit and check the controller displays room temperature.

If this unit cannot display room temperature, this unit is broken. Please remove this unit and contact our service center. (When the input mode is thermocouple, it is available to display room temperature.)

#### • In case of indicating "Error" in display

This Error message is indicated in case of damaging inner chip program data by outer strong noise.

In this case, please send the unit to our after service center after removing the unit from system.

Noise protection is designed in this unit, but it does not stand up strong noise continuously. If bigger noise than specified (Max. 2kV) flows in the unit, it can be damaged.

### ◎ Cautions during use

- Follow instructions in 'Cautions during Use'. Otherwise, It may cause unexpected accidents.
- Check the polarity of the terminals before wiring the temperature sensor.
  - For RTD temperature sensor, wire it as 3-wire type, using cables in same thickness and length.
  - For thermocouple (CT) temperature sensor, use the designated compensation wire for extending wire.
- Keep away from high voltage lines or power lines to prevent inductive noise.
  - In case installing power line and input signal line closely, use line filter or varistor at power line and shielded wire at input signal line.
  - Do not use near the equipment which generates strong magnetic force or high frequency noise.
- Do not apply excessive power when connecting or disconnecting the connectors of the product.
- Install a power switch or circuit breaker in the easily accessible place for supplying or disconnecting the power.
- Do not use the unit for other purpose (e.g. voltmeter, ammeter), but temperature controller.
- When changing the input sensor, turn off the power first before changing.
  - After changing the input sensor, modify the value of the corresponding parameter.
- 24VAC, 24-48VDC power supply should be insulated and limited voltage/current or Class 2, SELV power supply device.
- Do not overlapping communication line and power line.
  - Use twisted pair wire for communication line and connect ferrite bead at each end of line to reduce the effect of external noise.
- Make a required space around the unit for radiation of heat.
  - For accurate temperature measurement, warm up the unit over 20 min after turning on the power.
- Make sure that power supply voltage reaches to the rated voltage within 2 sec after supplying power.
- Do not wire to terminals which are not used.
- This unit may be used in the following environments.
  - ①Indoors (in the environment condition rated in 'Specifications')
  - ②Altitude max. 2,000m
  - ③Pollution degree 2
  - ④Installation category II

# Autonics

## Controlador de Temperatura PID de alta velocidad

### SERIE TK4

#### MANUAL DE INSTRUCCIONES



Muchas gracias por elegir los productos Autonics.  
**Por su seguridad, por favor lea lo siguiente antes de usar el producto.**

### Precauciones de Seguridad

Por favor tome en cuenta todas las especificaciones de seguridad para una operación segura y adecuada del producto y así evitar peligros.

El símbolo representa precaución debido a circunstancias especiales en donde puede haber peligro.

**Advertencia** Si no se siguen correctamente las instrucciones, puede causar una lesión grave o la muerte.

**Precaución** Si no se siguen correctamente las instrucciones, puede causar lesiones en la persona o daños en el producto.

### Advertencia

- El dispositivo de seguridad fail-safe se deberá instalar cuando se use la unidad con maquinaria que pueda causar serios daños o pérdida económica sustancial. (e.j. control de alimentación nuclear, equipo médico, barcos, vehículos, ferrocarriles, aviones, equipos de combustión, equipos de seguridad, dispositivos de prevención contra desastres/crimes, etc.) Puede causar un incendio, lesiones personales o pérdida económica si no se siguen correctamente las instrucciones.
- Instalar en un panel de dispositivos fail-safe se deberá de instalar cuando se use la unidad con maquinaria que pueda causar serios daños o pérdida económica sustancial. (e.j. control de alimentación nuclear, equipo médico, barcos, vehículos, ferrocarriles, aviones, equipos de combustión, equipos de seguridad, dispositivos de prevención contra desastres/crimes, etc.) Puede causar un incendio, lesiones personales o pérdida económica si no se siguen correctamente las instrucciones.
- Usar la unidad tomando en cuenta las especificaciones. Puede causar un choque eléctrico o un incendio.
- Revisar las "Conexiones" antes de cablear. Puede causar un incendio.
- No desarme o modifique la unidad. Puede causar un choque eléctrico o un incendio.

### Precaución

- Al conectar la entrada de alimentación y la salida a relevador, use un cable AWG 20(0.50mm<sup>2</sup>) o mayor y apriete el tornillo terminal con un torque de 0.74-0.90Nm. Al conectar la entrada del sensor y el cable de comunicación sin cable dedicado, use cable AWG 28-16 o mayor y apriete el tornillo terminal con un torque de 0.74-0.90Nm. Puede causar un incendio o un mal funcionamiento debido a fallas de contacto.
- Usar la unidad tomando en cuenta las especificaciones. Puede causar un incendio o dañar el producto si no se siguen correctamente.
- Usar una franela seca para limpiar la unidad, no agua o solventes orgánicos. Puede causar un incendio o un choque eléctrico.
- No usar la unidad en lugares cerca de inflamables/explosivos/gas corrosivo, humedad, rayos directos del sol, calor radiante, vibración, impacto o salinidad. Puede causar un incendio o una explosión.
- No permitir la entrada de residuos de cables, polvo, chips metálicos dentro de la unidad. Puede causar un incendio o dañar el producto.

### Información para seleccionar

TK	4	N	-1	4	R	N
Salida de control OUT2 <sup>2</sup>	Estándar	N	Ninguno	*Seleccionar en caso de control estándar (Calefacción o Refrigeración)		
Salida de control OUT1 <sup>2</sup>	R	R	Salida a relevador			
Alimentación	C	C	Salida de corriente o salida drive SSR			
	2	2	Salida a relevador			
	4	4	Salida drive SSR/Estándar ON/OFF, Control de ciclo, Control de fase			
	4	4	Salida de corriente o salida drive SSR			
	2	2	24VCA 50/60Hz, 24-48VCC			
	4	4	100-240VCA 50/60Hz			
Salida opcional <sup>1</sup>	N	N	Salida de 1 alarma+Entrada TC <sup>10</sup>			
	1	1	Calefacción y Refrigeración			
	2	2	Salida de 2 alarma <sup>11</sup>			
	2	2	Salida de 1 alarma + 2 alarma			
	2	2	Salida de 1 alarma + Entrada Digital (DI-1, DI-2)			
	N	N	Calefacción y Refrigeración			
	R	R	Salida de 1 alarma + Salida de transmisión			
	C	C	Calefacción y Refrigeración			
	T	T	Salida de transmisión			
	E	E	Estándar			
	S	S	11 Salida de alarma + Salida de comunicación RS485			
	R	R	Calefacción y Refrigeración			
	T	T	Salida de comunicación RS485			
	SP	SP	Salida de 1 alarma			
	S	S	Salida de 1 alarma			
	M	M	Salida de 1 alarma + 2 alarma			
	W	W	Salida de 1 alarma + Salida de transmisión PV			
	H	H	Salida de 1 alarma + 2 alarma + Salida de transmisión PV			
	L	L	Salida de 1 alarma + 2 alarma + Salida de comunicación RS485			
	D	D	Salida de 1 alarma + 2 alarma + Entrada Digital (DI-1, DI-2) <sup>12</sup>			
Tamaño	N	N	DIN W48 x H24mm			
	SP	SP	DIN W48 x H48mm(Tipo enchufe) <sup>13</sup>			
	S	S	DIN W48 x H48mm(Tipo bloque de terminales)			
	M	M	DIN W72 x H72mm			
	W	W	DIN W96 x H48mm			
	H	H	DIN W48 x H96mm			
	L	L	DIN W96 x H96mm			
Dígitos	4	4	9999(4-dígitos)			
Modelo	TK	TK	Temperatura / Controlador de Proceso			

1. En el caso de la serie TK4N, TK4SP la opción de salida está limitada debido al número de terminales.  
 2. La letra "S" representa modelos con salida drive SSR con control de función SSRP (ON/OFF estándar, ciclo, fase) disponible. La letra "C" representa la corriente seleccionada y los modelos con salida drive SSR.  
 3. Selección de la letra "R" o "C" en caso de usar control de refrigeración y calefacción y la letra "N" en caso de usar control estándar.  
 4. No disponible para modelos con voltaje CA/CC.  
 5. No disponible para la Serie TK4N.  
 6. La entrada TC de la Serie TK4N, solo se encuentra disponible en modelo estándar, que cuenta con salida de alarma 1.  
 7. El Modelo de calentamiento y enfriamiento de TK4N-1[ ] Solo tiene salida 2 de Alarma.  
 8. La terminal de salida OUT2 se usa como terminal de entrada DI-2, solo para la Serie TK4S-DI-2.  
 9. Sockets para TK4SP (PC-11, PS-11(N)) se vende por separado.  
 10. Shaded descriptions are upgraded or added functions from the before TK Series.  
 11. Las especificaciones anteriores pueden cambiar sin previo aviso o unos modelos pueden suspenderse.  
 12. Asegúrese de seguir las precaución escritas en el manual de instrucciones, manual de usuario y descripción técnica (catálogo y página principal).

### Especificaciones

Serie	TK4N	TK4SP	TK4S	TK4M	TK4W	TK4H	TK4L
Alimentación	CA	100-240VCA~50/60Hz	CA/CC	24VCA~50/60Hz, 24-48VCC			
Rango de voltaje disponible	90 a 110% de voltaje nominal						
Consumo de alimentación	CA	Max. 6VA	Max. 8VA				
	CA/CC		Max. 8VA (24VCA 50/60Hz), max. 5W (24-48VCC)				
Método del display	7 Segmentos (PV: rojo, SV: verde), LED de otra parte del display (verde, amarillo, rojo)						
Tamaño del PV (W×H)	4.5×7.2mm	7.0×14.0mm	4.5×7.2mm	8.5×17.0mm	8.5×17.0mm	11.0×22.0mm	11.0×22.0mm
Tamaño del SV (W×H)	3.5×5.8mm	5.0×10.0mm	3.5×5.8mm	6.0×12.0mm	6.0×12.0mm	6.0×12.0mm	7.0×14.0mm
RTD	JPT 100Ω, DPT 100Ω, DPT 50Ω, Cu 100Ω, Cu 50Ω, Niquel 1200(6 tipos)						
Tipo de entrada	Termopares	K, J, E, T, L, N, U, R, S, B, C, G, PLII(13 tipos)					
Analogico	Voltaje: 0 a 100mVCC, 0 a 5VCC, 1 a 5VCC, 0 a 10VCC (4 tipos)						
RTD	A temperatura (23°C±5°C): (PV ±0.3% ó ±1°C, selección del mayor) ±1-Dígito <sup>1</sup> Fuera del rango de temperatura: (PV±0.5% ó ±2°C, selección del mayor) ±1-Dígito En el caso de la Serie TK4SP, se agregará ±1°C.						
Precisión del display	Termopares	A temperatura (23°C ± 5°C): ± 0.3%F.S. ± 1-Dígito Fuera del rango de temperatura: ± 0.5%F.S. ± 1-Dígito					
Analogico	A temperatura (23°C ± 5°C): ± 0.3%F.S. ± 1-Dígito Fuera del rango de temperatura: ± 0.5%F.S. ± 1-Dígito						
Entrada CT	± 5%F.S. ± 1Dígito						
Salida de control	Relevador	OUT1, OUT2: 250VCA~3A 1a, 30VCC=3A 1a					
SSR	Max. 11VCC±2V 20mA						
Corriente	4-20mAACC ó 0-20mAACC (carga 500Ω max.)						
Salida de alarma	Relevador	AL1, AL2: 250VCA~3A 1a x TK4N AL2: 250VCA~0.5A, 1a (max. 124VA), TK4SP: Sólo AL1					
Salida alterna	Transmisión	4-20mAACC (carga: max. 500Ω, precisión: ±0.3%F.S.)					
Comunicación	Salida de comunicación RS485 (Modbus RTU)						
CT	0.0-50.0A (rango de medición del valor de corriente de calentador primario) x Ratio CT = 1/1000 (excepto TK4SP)						
Entrada opcional	Entrada de contacto	ON - max. 2kΩ, OFF - min. 90kΩ Sin entrada de contacto: voltaje residual - ON max. 1.0VCC, corriente de fuga - OFF max. 0.1mA Flujo de corriente: aprox. 0.5mA por entrada x TK4S/M-1EA (TK4S-DI-1)-2EA, TK4SP-Ninguno, TK4N/H/W/L-2EA					
Entrada digital	Entrada digital						
Tipo de control	Calefacción, Refrigeración	Modo de control ON/OFF, P, PI, PD, PID					
Histéresis	Termopares/RTD: 1 a 100°C/F (0.1 a 100.0°C/F) variable - Analógica: 1 a 100-Dígitos						
Banda proporcional(P)	0.1 a 999.9°C/F (0.1 a 999.9%)						
Tiempo integral(I)	0 a 9999 seg						
Tiempo derivativo(D)	0 a 9999 seg						
Periodo de control(T)	Salida a relevador, Salida drive SSR: 0.1 a 120.0 seg Salida de corriente+Salida drive SSR: 1.0 a 120.0 seg						
Valor de reinicio manual	0.0 a 100.0%						
Periodo de muestreo	50ms						
Rigidez dieléctrica	2000VCA 50/60Hz for 1 min (entre la terminal de alimentación y la terminal de entrada)						
Resistencia de vibración	0.75mm de amplitud a frecuencia de 5 a 55Hz (por 1 min) en cada una de las direcciones X, Y, Z por 2 horas						
Ciclo de vida del relé	Mecánico	OUT1/2: sobre 5,000,000 veces - AL1/2: sobre 20,000,000 veces (TK4H/W/L: sobre 5,000,000 veces)					
Eléctrico	OUT1/2, AL1/2: sobre 100,000 veces						
Resistencia de aislamiento	Sobre 100MΩ (a 500VCC megger)						
Resistencia al ruido	Ruido de onda cuadrada por simulador de ruido (ancho de pulso 1μs) ±2kV fase-R, fase-S						
Retención de memoria	Aprox. 10 años (cuando usa memoria de semiconductor no volátil)						
Entorno	Temperatura ambiente	-10 a 50°C, almacenamiento: -20 a 60°C					
Humedad ambiente	35 a 85%RH, almacenamiento 35 a 85%RH						
Protección	IP65 (panel frontal) x TK4SP: IP50 (panel frontal)						
Tipo de aislamiento	El doble aislamiento o aislamiento reforzado (marque: R) Rigidez dieléctrica entre la parte de entrada de medida y la parte de potencia : 2kV)						
Certificación	CE, RoHS						
Peso <sup>2</sup>	Aprox. 140g (aprox. 70g)	Aprox. 130g (aprox. 85g)	Aprox. 150g (aprox. 105g)	Aprox. 210g (aprox. 140g)	Aprox. 211g (aprox. 141g)	Aprox. 284g (aprox. 198g)	Aprox. 284g (aprox. 198g)

1: A temperatura (23°C±5°C)  
 TC tipo K, J, T, N, E, debajo de -100°C / TC L, U, PL II, Cu500, DPT500; (PV±0.3% ó ±2°C, selección del mayor) ±1-Dígito  
 TC tipo C, G / tipo TC R, S, debajo de 200°C: (PV±0.3% ó ±3°C, selección del mayor) ±1-Dígito  
 TC tipo B, debajo de 400°C: no hay estándares de precisión.  
 2: Fuera del rango de temperatura  
 RTD Cu500, DPT500: (PV±0.5% ó ±3°C, selección del mayor) ±1-Dígito  
 TC R, S, B, C, G: (PV ±0.5% ó ±5°C, selección del mayor) ±1-Dígito  
 Otros, debajo -100°C: dentro de ±5°C  
 En caso de la serie TK4SP, se agregará ±1°C.  
 3: El peso entre paréntesis es sólo unidad de peso  
 La resistencia ambiental se encuentra en estado sin congelación o condensación.

### Descripción de partes

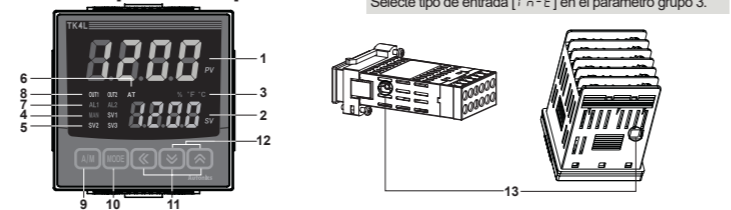

- Display de PV: Muestra la temperatura actual (PV) en el modo RUN y parámetros en el modo de Ajuste.
- Display de SV: Muestra el ajuste del valor de temperatura (SV) para controlar el modo RUN y cada ajuste de parámetros grupo 3. (En caso de la Serie TK4N, no aplica el %)
- Indicador de Unidad de Temperatura (C/F/%): Muestra la unidad de temperatura actual. Se puede ajustar en parámetros grupo 3.
- Indicador de Control Manual: Estará ENCENDIDO en caso de seleccionar el modo de control manual.
- Indicador de Multi SV: Una de las lámparas de SV1 a 3 estará ENCENDIDA en caso de seleccionar la función multi SV.
- Indicador de Auto-Tuning: Estará parpadeando cada segundo durante el Auto-tuning.
- Indicador de salida de Alarma (AL1,AL2): Estará ENCENDIDA cuando cada salida de alarma se encuentre en ENCENDIDO.
- Indicador de salida de control(OUT1,OUT2): Estará ENCENDIDO cuando la salida de control este ENCENDIDA.  
 x En caso del control Ciclo/Pase de la salida SSRP(TK4-4S: ), está ENCENDIDO cuando MV sea mayor a 5.0%  
 x En caso de seleccionar salida de corriente (4-20mAACC, 0-20mAACC).  
 - Modo de control manual: Siempre estará en ENCENDIDO, excepto si MV es 0.0%.  
 - Modo de control automático: Estará en ENCENDIDO cuando MV sea mayor a 3.0%, y en APAGADO cuando MV sea menor a 2.0%.
- La tecla [ ]: Se usa cuando se conmuta el modo de control automático ↔ modo de control manual  
 x TK4N/S/SP no tiene [ ], la tecla [ ] se usará simultáneamente para la misma función
- Las teclas [ ]: Se usa al entrar en el modo de cambio del valor de ajuste, regresar a modo RUN, mover parámetro y guardar el valor ajustado (Digito).
- La tecla [ ]: Se usa al entrar en el modo de ajuste de parámetros y parámetros de movimiento.
- La tecla entrada digital: En el caso de pulsar durante 3 seg, al mismo tiempo, operará el función (RUN/STOP, alarma clara, Auto-tuning) con la tecla entrada digital en el parámetro 5 grupo.
- Puerto cargador de PC: Es el puerto cargador de PC de comunicación serial para configurar parámetros con el DAQMaster instalado en la PC. Úselo para conectar SCM-US (El convertidor USB/Seria, se vende por separado).

### Montaje del producto

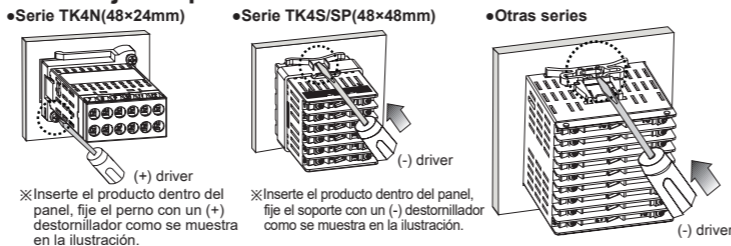

### Conexiones

x Modelo estándar solo tiene los terminales sombreados.  
 x Modo de funcionamiento de la calefacción y refrigeración OUT2 modelo de salida de relé está calentando o enfriando. OUT2 está disponible como salida de alarma 3 (Excepto Series TK4N).  
 x Modo de funcionamiento de la calefacción y refrigeración OUT2 modelo de salida de corriente está calentando o enfriando. OUT2 está disponible como salida de transmisión 2.  
 x Para la terminal, seleccione la terminal de la siguiente forma.



### Serie TK4N

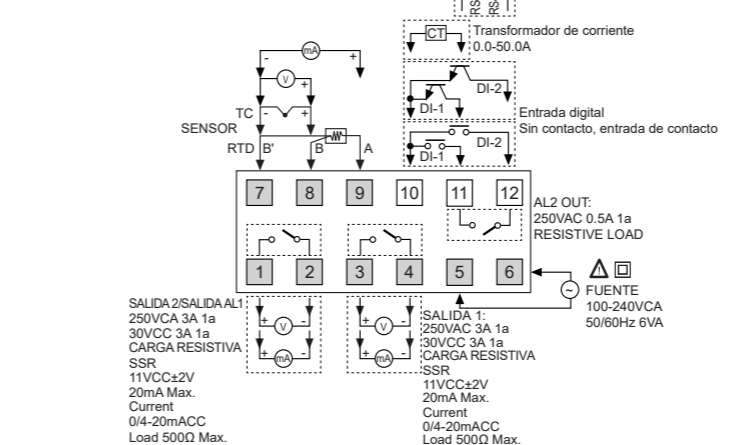

### Serie TK4S

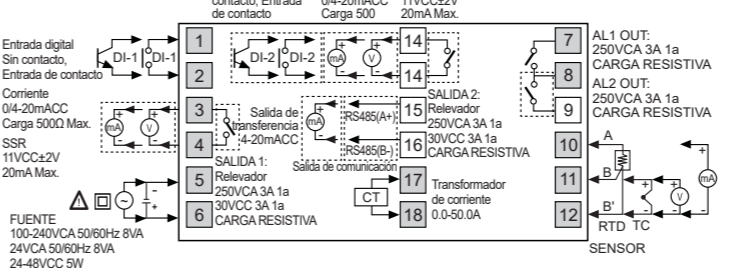

### Dimensiones

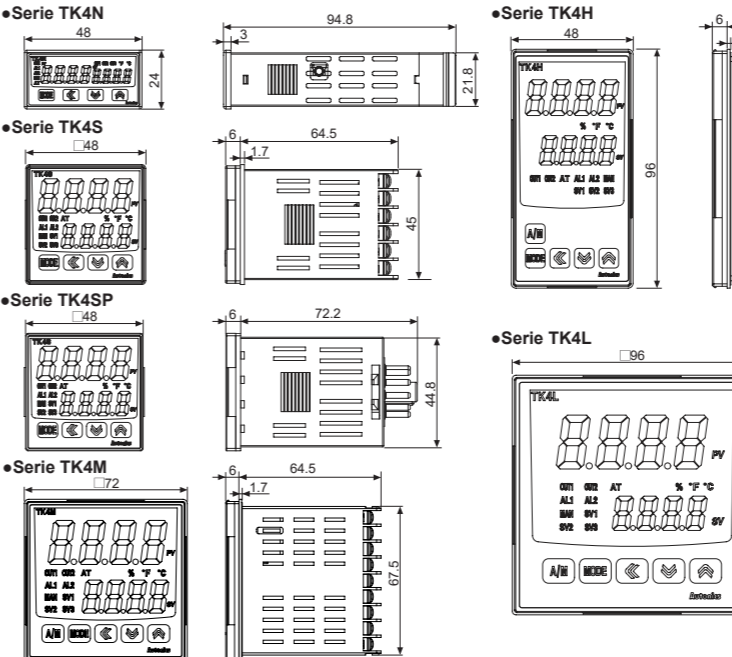

### Soporte

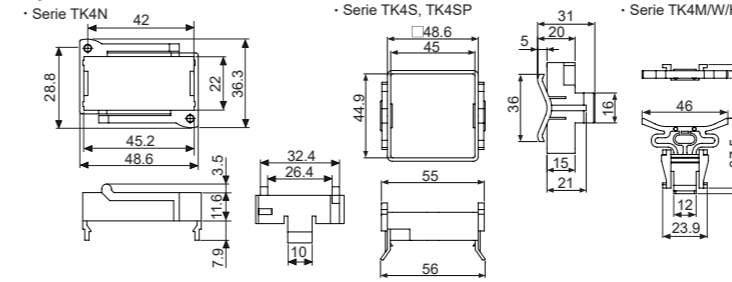

### Serie TK4SP

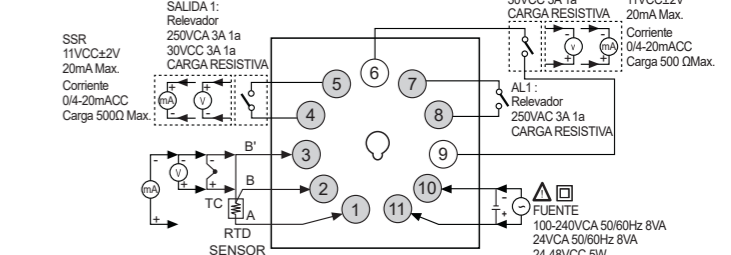

### Serie TK4M

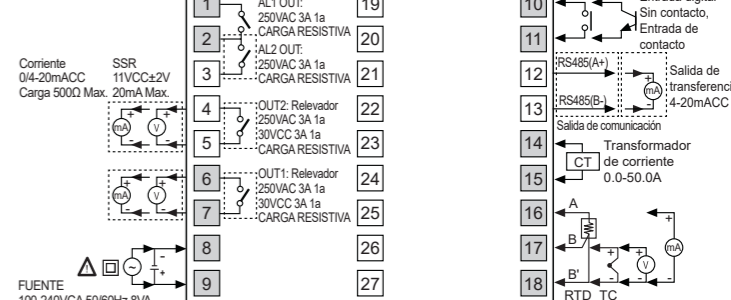

### Serie TK4H, TK4W, TK4L

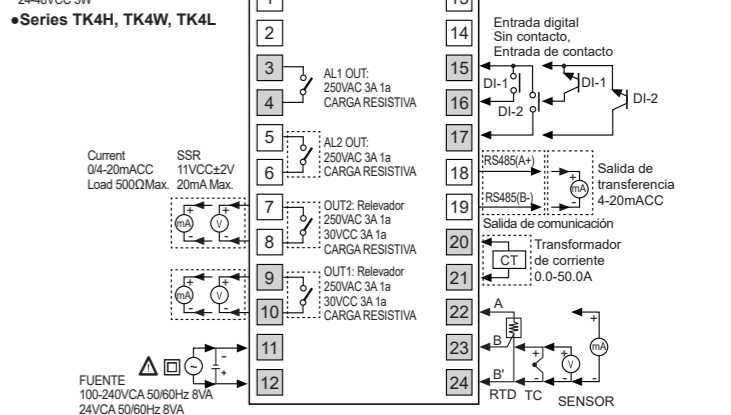

### Cubierta terminal (Se vende por separado)

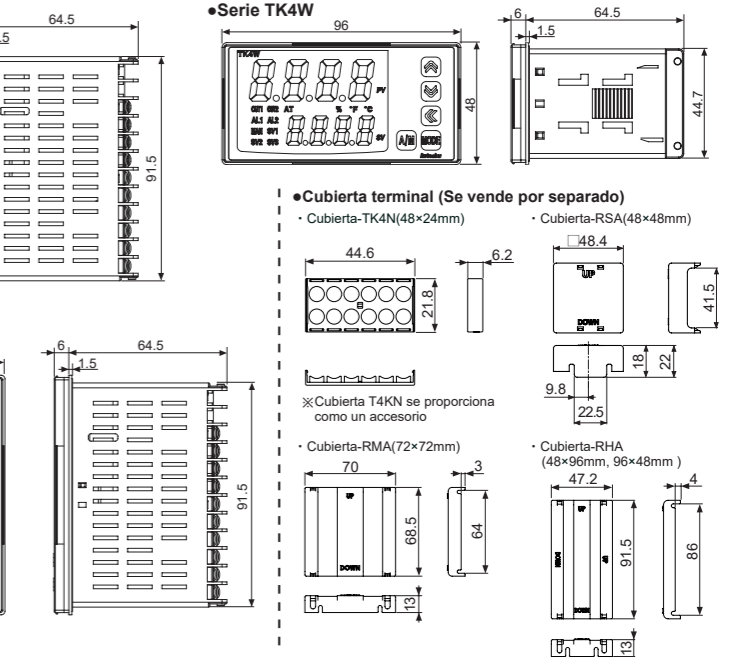

### Corte del panel

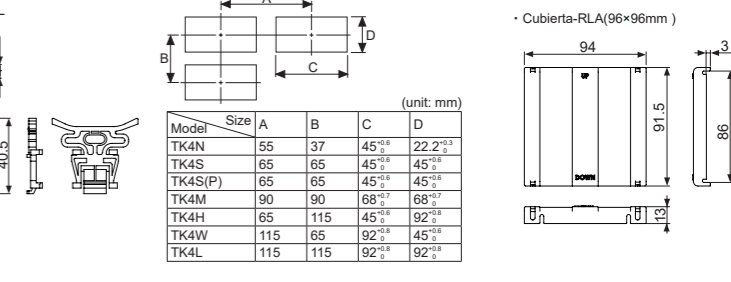

## Diagrama de ujo del grupo de ajustes

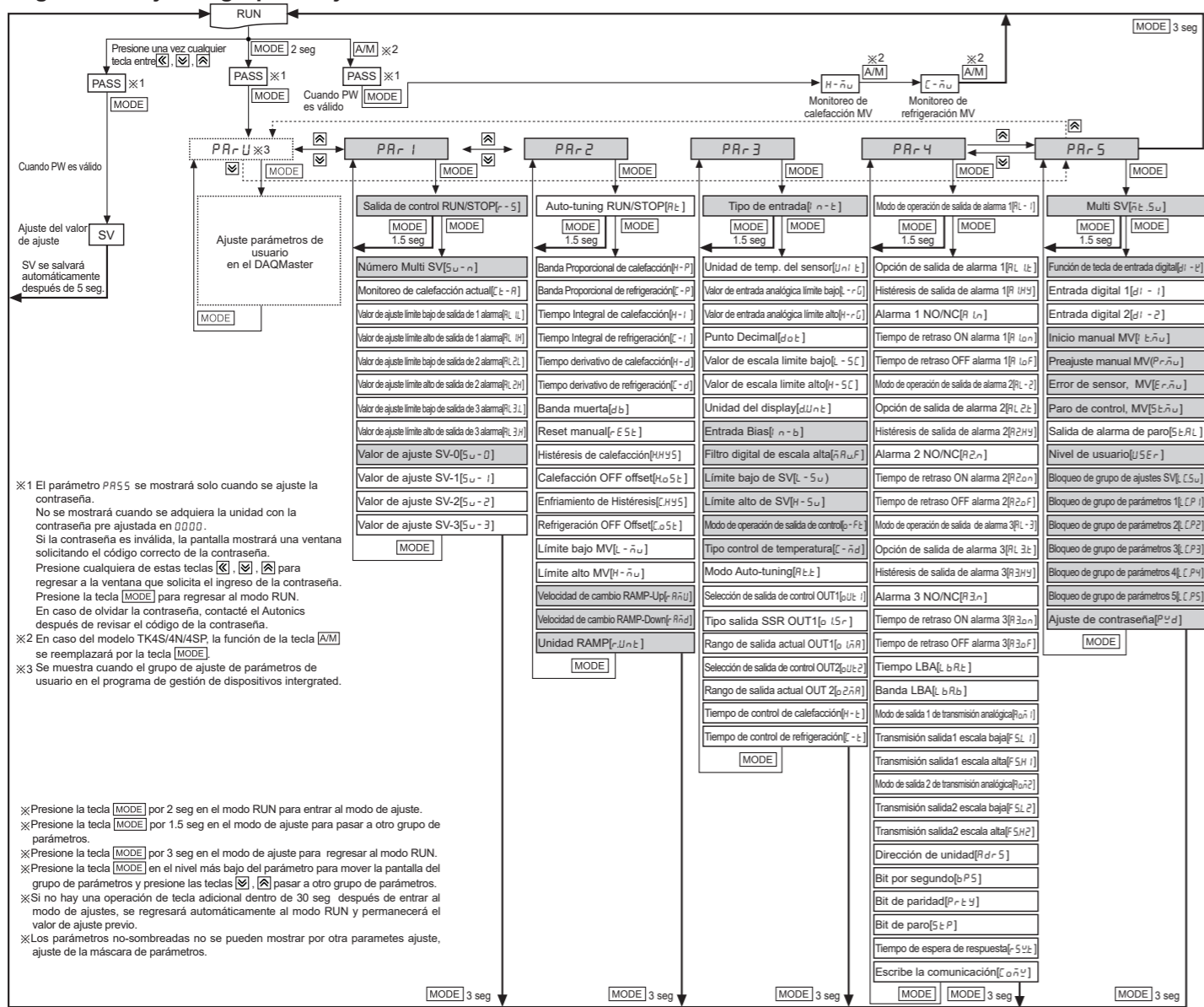

- ×1 El parámetro PR55 se mostrará solo cuando se ajuste la contraseña. No se mostrará cuando se adquiera la unidad con la contraseña preajustada en 0000. Si la contraseña es inválida, la pantalla mostrará una ventana solicitando el código correcto de la contraseña. Presione cualquiera de estas teclas [K], [L], [M] para regresar a la ventana que solicita el ingreso de la contraseña. Presione la tecla [MODE] para regresar al modo RUN. En caso de olvidar la contraseña, contacte el Autonics después de revisar el código de la contraseña.
- ×2 En caso del modelo TK4S/4N/4SP, la función de la tecla [A/M] se reemplazará por la tecla [MODE].
- ×3 Se muestra cuando el grupo de ajuste de parámetros de usuario en el programa de gestión de dispositivos integrados.

- × Presione la tecla [MODE] por 2 seg en el modo RUN para entrar al modo de ajuste.
- × Presione la tecla [MODE] por 1.5 seg en el modo de ajuste para pasar a otro grupo de parámetros.
- × Presione la tecla [MODE] por 3 seg en el modo de ajuste para regresar al modo RUN.
- × Presione la tecla [MODE] en el nivel más bajo del parámetro para mover la pantalla del grupo de parámetros y presione las teclas [K], [L], [M] para pasar a otro grupo de parámetros.
- × Si no hay una operación de tecla adicional dentro de 30 seg después de entrar al modo de ajustes, se regresará automáticamente al modo RUN y permanecerá el valor de ajuste previo.
- × Los parámetros no-sombreados no se pueden mostrar por otra parámetros ajuste, ajuste de la máscara de parámetros.

## Sensor y rango de entrada

Sensor de entrada	Punto	Display	Rango de entrada(°C)	Rango de entrada(°F)		
Termopares	K(CA)	1	ECRH	-200 a 1350	-328 a 2463	
		0.1	ECRL	-199.9 a 999.9	-199.9 a 999.9	
	J(IC)	1	JICH	-200 a 800	-328 a 1472	
		0.1	JICL	-199.9 a 800.0	-199.9 a 999.9	
	E(CR)	1	ECRH	-200 a 800	-328 a 1472	
		0.1	ECRL	-199.9 a 800.0	-199.9 a 999.9	
	T(CC)	1	ECCH	-200 a 400	-328 a 752	
		0.1	ECCL	-199.9 a 400.0	-199.9 a 752.0	
	RTD	B(PR)	1	bPR	0 a 1800	32 a 3272
			rPR	0 a 1750	32 a 3182	
		S(PR)	1	sPR	0 a 1750	32 a 3182
			n(NN)	1	nNN	-200 a 1300
C(TT)×1		1	CTE	0 a 2300	32 a 4172	
		G(TT)×2	1	GTE	0 a 2300	32 a 4172
L(IC)		1	LICH	-200 a 900	-328 a 1652	
		0.1	LICL	-199.9 a 900.0	-199.9 a 999.9	
U(CC)		1	UCCH	-200 a 400	-328 a 752	
		0.1	UCCL	-199.9 a 400.0	-199.9 a 752.0	
Platínel II	1	PLI	0 a 1390	32 a 2534		
	Cu 50Ω	0.1	CU5	-199.9 a 200.0	-199.9 a 392.0	
Cu 100Ω		0.1	CU10	-199.9 a 200.0	-199.9 a 392.0	
	JPT 100Ω	1	JPTH	-200 a 650	-328 a 1202	
0.1		JPTL	-199.9 a 650.0	-199.9 a 999.9		
DPT 50Ω	0.1	dPT5	-199.9 a 600.0	-199.9 a 999.9		
	DPT 100Ω	1	dPTH	-200 a 650	-328 a 1202	
0.1		dPTL	-199.9 a 650.0	-199.9 a 999.9		
Nickel 120Ω	1	nI2	-80 a 200	-112 a 392		
	Analógico	0 to 10V	AV1	-1999 to 9999 (Display point will be changed according to decimal point position.)		
0 to 5V		AV2				
1 to 5V		AV3				
0 to 100mV		AV4				
Corriente	0 to 20mA	AA1				
	4 to 20mA	AA2				

×1: Igual que el sensor W5 ya existente (TT) ×2: Igual que el sensor W ya existente(TT).

## Display de panel frontal cuando se ENCIENDE



## Diagrama de flujo para ajuste SV

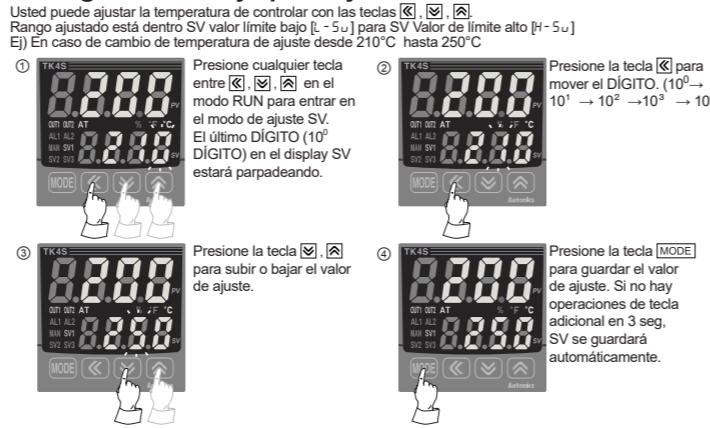

## Inicialización de parámetros

Presione las teclas [K] + [L] + [M] para inicializar todos los parámetros en la memoria al valor predeterminado. Ajuste el parámetro [1 n t] a [E 5] para inicializar todos los parámetros. En caso de que la función de la contraseña este encendida, se requiere ingresar una contraseña válida para inicializar los parámetros. También se inicializa la contraseña.

## Máscara de parámetros

Esta función es capaz de ocultar los parámetros innecesarios al entorno del usuario, los parámetros de uso menos frecuente en el grupo de ajuste de parámetros. Puede configurar esto en el programa integrado de dispositivos (DAQMaster). Aunque los parámetros enmascarados no se muestran en el grupo de ajuste de parámetros, se aplican los valores de configuración de parámetros. Para obtener más información, consulte el manual de usuario maestro DAQMaster. Visite nuestro sitio web (www.autonics.com) para descargar el programa principal adquisición de datos y el manual del usuario.

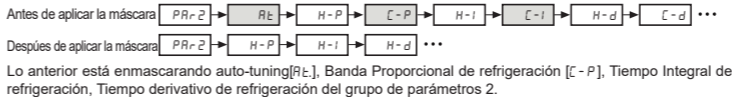

## Ajuste de parámetro grupo de usuario

Esta función es capaz de establecer los parámetros que se utilizan con frecuencia para el grupo de parámetros de usuario. Usted puede ajustar rápida y fácilmente ajuste de parámetros. El grupo de parámetros de usuario puede tener hasta 30 parámetros en el programa integrado de dispositivos (DAQMaster). Para obtener más información, consulte el manual de usuario maestro DAQMaster. Visite nuestro sitio web (www.autonics.com) para descargar el programa principal adquisición de datos y el manual del usuario.

### Run mode

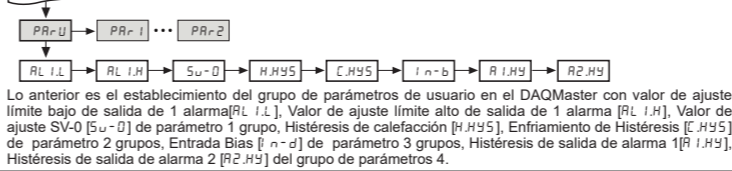

## Auto-tuning

Auto-tuning mide características térmicas el control del sujeto y tasa de respuesta térmica, y luego determina la constante de tiempo P.D necesario. Aplicación de la constante de tiempo PID se da cuenta de respuesta de rápido y control de la temperatura alta precisión. (Cuando se ajusta el tipo de control [C - n d] a [P i d], parece.) Ajuste el parámetro [R t] a [n] en el grupo de ajuste de parámetros 2 para empezar auto-tuning. Ajuste el parámetro [R t] a [o F F] para detener el auto-tuning. (Se guardarán los valores P.I.D ajustados previamente.) Cuando ocurre un error [o P e r] durante el auto-tuning, auto-tuning se detendrá automáticamente y se guardará la constante de tiempo PID previa. Durante la operación de auto-tuning, parámetros enteros solamente están disponibles para comprobar.

## Alarma

### Alarma operación

Modo	Nombre	Alarma operación	Descripción
o F F	—	—	Sin salida de alarma
d u C C	Alarma de desviación de límite-alto	OFF   H   ON SV 100°C, PV 110°C Desviación alta: fijado como 10°C	Si ocurre una desviación mayor que el valor de ajuste entre PV y SV de la temperatura de desviación, la salida estará ENCENDIDA.
J J d u	Alarma por límite de desviación bajo	ON   H   OFF PV 90°C, SV 100°C Desviación baja: fijado como 10°C	Si ocurre una desviación menor que el valor de ajuste entre PV y SV de la temperatura de desviación, la salida estará ENCENDIDA.
J d u C	Alarma por límite de desviación alto/bajo	ON   H   OFF PV 90°C, SV 100°C, 120°C Desviación baja: fijado como 10°C, Desviación alta: fijado como 20°C	Si ocurre una desviación menor o mayor que el valor de ajuste entre PV y SV de la temperatura de desviación, la salida estará APAGADA.
C d u	Alarma por límite de desviación alto/bajo (Salida Invertida)	OFF   H   ON PV 90°C, SV 100°C, 120°C Desviación baja: fijado como 10°C, Desviación alta: fijado como 20°C	Si ocurre una desviación menor o mayor que el valor de ajuste entre PV y SV de la temperatura de desviación, la salida estará ENCENDIDA.
P u C C	Alarma por límite de valor absoluto alto/bajo	OFF   H   ON PV 90°C, SV 100°C Valor absoluto: Set as 90°C	Si PV es igual o mayor que el valor absoluto de la alarma de temperatura, la salida estará ENCENDIDA.
J J P u	Alarma por límite de valor absoluto bajo	ON   H   OFF PV 90°C, SV 100°C Valor absoluto: Set as 90°C	Si PV es igual o menor que el valor absoluto de la alarma de temperatura, la salida estará ENCENDIDA.
L b R	Alarma de rotura de lazo	—	Estará ENCENDIDA cuando detecte una rotura de lazo.
5 b R	Alarma de rotura de sensor	—	Estará ENCENDIDA cuando detecte la desconexión del sensor.
H b R	Alarma de rotura de calentador	—	Estará ENCENDIDA cuando CT detecta una rotura de calentador.

×H: Salida de alarma □ Histéresis [R t H Y]

### Opción de alarma

Modo	Nombre	Descripción
R L - A	Alarma estándar	Si se trata de una condición de alarma, la salida de alarma está en ON. Si se trata de una condición de alarma clara, la salida de alarma está en OFF.
R L - b	mantenimiento de alarma	Si se trata de una condición de alarma, la salida de alarma está en ON y mantiene el estado ON. (Salida de alarma HOLD)
R L - C	Secuencia de espera 1	Se ignora la primera alarma y desdela segunda condición de alarma, la alarma estándar funciona. Cuando se suministre energía y es una condición de alarma, esta primera condición de alarma se ignora y desde la segunda condición de alarma, la alarma estándar funciona.
R L - d	Alarma enclavada y Secuencia en espera 1	Si se trata de una condición de alarma, opera como alarma enclavada y alarma en secuencia de espera. Cuando se suministre energía y es una condición de alarma, esta primera condición de alarma se ignora y desde la segunda condición de alarma, opera la alarma de enclavamiento.
R L - E	Secuencia en espera 2	Se ignora la primera alarma y desdela segunda condición de alarma, la alarma estándar funciona. Cuando se vuelve a aplicar la secuencia de espera y si es condición de alarma, la alarma de salida no enciende. Después de limpiar el estado de alarma, la alarma estándar funciona.
R L - F	Alarma enclavada y Secuencia en espera 2	La operación básica es igual que la alarma de enclavamiento y la secuencia en espera 1. No solo opera por alimentación ON/OFF; también por valor de ajuste de alarma, o cambio de opción de alarma. Cuando se vuelve a aplicar la secuencia de espera y si es condición de alarma, la alarma de salida no enciende. Después de limpiar el estado de alarma, la alarma enclavada funciona.

× Cuando se vuelve a aplicar la secuencia de espera para secuencia en espera1, alarma de enclavamiento y secuencia en espera1: Encendido Cuando se vuelve a aplicar la secuencia de espera para secuencia en espera2, alarma de enclavamiento y secuencia en espera2: Encendido cambio de temperatura ajustada, temperatura de la alarma [R L 1, R L 2] u operación de alarma [R L - 1, R L - 2], switcheo de modo de PARO a modo RUN.

## Ajustes de fábrica

Grupo de ajustes SV [5 u ]		Parámetros del ingreso de contraseña	
Parámetro	Ajustes de fábrica	Parámetro	Ajustes de fábrica
5 u	0	PASS	0001

Grupo de ajuste de parámetros 1 [P R 1 ]			
Parámetro	Ajustes de fábrica	Parámetro	Ajustes de fábrica
r - 5	r n	AL LH	1550
5 u - n	5 u - 0	AL 2L	1550
C t - A	0.0	AL 2H	1550
AL LL	1550	AL 3L	1550

### Grupo de ajuste de parámetros 2 [P R 2 ]

Parámetro	Ajustes de fábrica	Parámetro	Ajustes de fábrica	Parámetro	Ajustes de fábrica	Parámetro	Ajustes de fábrica
R t	o F F	H - d	0000	H o 5 t	000	r A n u	000
H - P	0 10.0	C - d	0000	C H Y 5	002	r A n d	000
C - P	0 10.0	d b	0000	C o 5 t	000	r u n t	n i n
H - I	0 00.0	r E 5 t	0500	L - n u	+000		
C - I	0000	H H Y 5	002	H - n u	1000		

### Grupo de ajuste de parámetros 3 [P R 3 ]

Parámetro	Ajustes de fábrica	Parámetro	Ajustes de fábrica	Parámetro	Ajustes de fábrica	Parámetro	Ajustes de fábrica
i n t	E C R H	H - 5 t	1000	o - F t	H E R t	o 15 r	5 t n d
U n t	0	d U n t	0.0		H - C	o 1 A R	4 - 20
L - r G	0000	i n - b	0000	C - n d	P i d	o U t 2	C U r r
H - r G	1000	A R o F	000.1		P P	o 2 A R	4 - 20
d o t	0.0	L - 5 u	-200	R t	t U n i	H - t	0 200 (Relator)
L - 5 C	0000	H - 5 u	1350	o U t 1	C U r r	C - t	0020 (SSR)

### Grupo de ajuste de parámetros 4 [P R 4 ]

Parámetro	Ajustes de fábrica	Parámetro	Ajustes de fábrica	Parámetro	Ajustes de fábrica	Parámetro	Ajustes de fábrica
AL - 1	d u C C	A 2 n	n o	L b R b	0000	b P 5	96
AL 1 t	AL - A	A 2 o n	0000	L b R b	002	P r t y	n o n e
A 1 H Y	00 1	A 2 o F	0000	A o n 1	P u	5 t P	2
A 1 n	n o	AL - 3	o F F	F S L 1	-200	r 5 Y t	20
A 1 o n	0000	AL 3 t	AL - A	F 5 H 1	1350	C o n y	E n R
A 1 o F	0000	A 3 H Y	00 1	A o n 2	P u		
AL - 2	J J d u	A 3 n	n o	F 5 L 2	-200		
AL 2 t	AL - A	A 3 o n	0000	F 5 H 2	1350		
A 2 H Y	00 1	A 3 o F	0000	A d - 5	0 1		

### Grupo de ajuste de parámetros 5 [P R 5 ]

Parámetro	Ajustes de fábrica	Parámetro	Ajustes de fábrica	Parámetro	Ajustes de fábrica	Parámetro	Ajustes de fábrica
n t 5 u	1	P r n u	0000	L L 5 u	o F F	L C P 5	o F F
d i - 2	5 t o P	E r n u	0000	L L P 1	o F F	P y d	0000
d i - 1	o F F	5 t n u	0000	L L P 2	o F F		
d i - 2	o F F	5 t R L	C o n t	L L P 3	o F F		
i t n u	R U t o	U 5 E r	5 t n d	L L P 4	o F F		

× Parámetros sombreados son para la calefacción y enfriamiento modelo.

## Manual del usuario

Para información más detallada e instrucciones, por favor consulte nuestro manual de usuario y el manual de usuario para comunicación y asegúrese de seguir las precauciones escritas en el descripción técnica (catálogo y página principal). Visite nuestro sitio web (www.autonics.com.mx) para descargar los manuales.

## Administración integral de dispositivos [DAQMaster]

DAQMaster es un programa de administración integral de dispositivos para un manejo múltiple práctico de parámetros y monitoreo de dispositivos. Visite nuestro sitio web (www.autonics.com) para descargar el manual del usuario y el programa de administración integrado de dispositivos DAQMaster.

Características	Especificaciones recomendadas
Sistema	PC IBM compatible con Pentium III o posterior
Sistema operativo	Microsoft Windows 98/NT/XP/Vista/7/8/10
Memoria	Min. 256MB
Disco duro	1GB en espacio del disco duro o más
VGA	Resolución de pantalla min. de 1024x768
Otros artículos	Puerto serial RS-232 (9Pin), puerto USB

## Precauciones de uso

- Seguir las especificaciones dentro de 'Precauciones de uso'. De otra manera, puede causar accidentes inesperados.
- Por favor cablear apropiadamente después de revisar la polaridad de la terminal al conectar el sensor de temperatura. Los sensores de temperatura RTD se deben de cablear a 3-hilos, usando cables del mismo grosor y longitud. Para termopares (CT), se debe de usar el cable de compensación designado.
- Mantenerlo alejado de altas líneas de voltaje o de alimentación para prevenir ruido inductivo. En caso de instalar cerca la línea de alimentación y la señal de entrada, use un filtro de línea o un varistor en la línea de alimentación y un cable blindado en la línea de señal de entrada. No usar cerca de equipos que generen fuertes campos magnéticos o ruido de alta frecuencia.
- No aplicar exceso de alimentación al conectar o desconectar los conectores de los productos.
- Instalar un interruptor de alimentación o un cortacircuitos en un lugar accesible para conectar o desconectar la alimentación.
- No usar esta unidad para otro propósito (e.g., voltímetro, amperímetro) ajenos al control de temperatura.
- Apagar el equipo antes de cambiar el sensor de entrada. Después de cambiar el sensor de entrada, modificar el valor de los parámetros correspondientes.
- La alimentación 24VCA, 24-48VCC deberá de ser aislada y tener un voltaje/corriente limitado o tipo Clase 2, dispositivo de alimentación SELV.
- No sobrepasar las líneas de alimentación y comunicación. Usar cable de par trenzado para la línea de comunicación y conectar un núcleo de ferrita en cada extremo de la línea para reducir el efecto del ruido externo.
- Requiere un espacio alrededor de la unidad para la radiación del calor. Para una medición de temperatura precisa, precalentar la unidad por sobre 20 minutos después de encenderla.
- Asegurar que el voltaje de alimentación encuentre el voltaje nominal dentro de 2 seg después de suministrar alimentación.
- No cablear a terminales sin uso.
- Esta unidad se debe de usar en los siguientes ambientes:
  - ① Interiores (En condiciones de ambiente dentro de las Especificaciones)
  - ② Máx. altitud. 2,000m
  - ③ Categoría de instalación II

## Productos principales

- Sensores fotoeléctricos
- Sensores de fibra óptica
- Sensores de puertas
- Sensores de puertas laterales
- Sensores de área
- Sensores de proximidad
- Sensores de presión
- Paneles Lógicos/Gráficos
- Conectores/Sockets
- Controladores de temperatura
- SSR/Controlador de potencia
- Transductores de humedad/temperatural
- Motors a pasos/drivers/controladores de movimiento
- Sistema de marcado láser (fibra, CO<sub>2</sub>, Nd: YAG)
- Sistema de soldadura por láser
- Medidores de pulsos/(ritmo)/tacómetros
- Unidades de display
- Controladores de sensores
- Fuentes de alimentación
- Control switches / Lámpara / Buzzers
- Bloque de terminales E/S / Cable
- Encoders rotativos
- Contadores
- Temporizadores
- Dispositivos de red de campo
- Medidores de panel
- Dispositivos de red de campo

**Autonics Corporation**  
<http://www.autonics.com>

■ MATRIZ :  
 18, Bansong-ro 513-beon-gil, Haeundae-gu, Busan  
 South Korea, 48002  
 TEL: 82-51-519-3232  
 ■ E-mail : sales@autonics.com

DRW170598AB