



Automatic power factor controller, 8 steps, icon display
DCRL8

Product designation

Product type designation

Auxiliary supply

Rated auxiliary supply voltage U_s

AC

min	VAC	100
Max	VAC	440

DC

min	VDC	110
Max	VDC	250

Auxiliary operating range

90...484VAC /
93.5...300VDC

Auxiliary rated frequency

Hz 50/60 $\pm 10\%$

Power consumption Max

VA 8.5

Power dissipation Max

W 3

Immunity time for microbreakings

ms <25

Voltage inputs

Rated voltage (U_e)

VAC 600VAC L-L
(rated max)

Operating range

50...720VAC L-L
(415VAC L-N)

Frequency range

Hz 45...65

Type of measure

True RMS value

No-voltage release

ms ≥ 8

Measurement input impedance

k Ω >15M Ω

Type of connection

Single phase, two
phase, three
phase with or
without neutral or
balanced three
phase system

Current inputs

Number of current input

Nr. 1

Type of input

Shunt supplied
by external
current
transformer (low
voltage). Max 5A

Measurement range

0.025...6A~ for
5A scale;
0.025...1.2A~ for
1A scale

Measurement method

True RMS value

Constant overload

le 1.2 le

Overload peak	A	50A for 1s
Burden per phase	W	<0.6VA
Measurement data		
Type of voltage and current measurement		True RMS value
Power factor adjustment		0.5ind...0.5cap.
Type of temperature sensor		Internal
Temperature measurement range	°C	0...+212
Relay outputs		
Number of relay output	Nr.	8 (up to 14 with EXP10 06 - EXP10 07)
Contact arrangement		7 NO-SPST + 1 C/O-SPDT
Rated current		5A 250V AC1
UL/CSA and IEC/EN 60947-5-1 designation		B300
Maximum current at common contact terminal	A	10
Maximum switching voltage	VAC	415
Electrical life (with rated load)	cycles	10 ⁵
Mechanical life	cycles	10 ⁷
Insulations		
Rated insulation voltage Ui IEC/EN	V	600
Rated impulse withstand voltage Uimp	kV	9.5
Operating frequency withstand voltage	kV	5.2
Functions		
Automatic recognition of current flow direction		Yes
4-quadrant operation		Yes
Master-Slave function		No
Independent auxiliary supply input		Yes
Three-phase voltage control		No
Current inputs		1
Dynamic (FAST) power factor correction		No
Power factor correction by single phase		No
Possibility of connecting inductive steps		No
Possibility of use in medium voltage		Yes
Possibility of phase-neutral insertion on a three-phase system		Yes
Analog outputs		No
Input programmable as function or external temperature sensor		No
USB communication interface		No
RS232 communication interface		Yes
Opto-isolated RS485 communication interface		Yes
Ethernet communication interface		Yes
Opto-isolated Profibus-DP interface		Yes
GPRS/GSM modem		No
Optical port on front for the connection of USB devices		Yes
Optical port on front for the connection of Wi-Fi devices		Yes
Fast setting of current transformer		Yes
Compatible with Xpress configuration and remote control software		Yes
Compatible with Synergy and Synergy Cloud, supervision and energy management software		Yes
Compatible with Sam1 App		Yes
Calendar-clock with backup reserve power		No
Data logging memory		No
Event logging: alarms, setup changes, etc.		No
Customisable internal counters		No

Connections

Type of terminal				Plug-in, removable
Conductor cross section	min	mm ²	0.2	
	Max	mm ²	2.5	
	min	AWG	24AWG (18AWG according to UL/CSA)	
	Max	AWG	12	
Tightening torque (Max)			Nm	0.56
			lbin	5

Ambient conditions

Temperature	Operating temperature			
	min	°C	-20	
	max	°C	+60	
	Storage temperature			
	min	°C	-30	
	max	°C	+80	
Relative humidity			%	<80%
Maximum Pollution degree				2
Overvoltage category				3
Measurement category				III

Climatic sequence	Z/ABDM (IEC/EN 60068-2-61)			
Shock resistance	15g (IEC/EN 60068-2-27)			
Vibration resistance	0.7g (IEC/EN 60068-2-6)			

Housing

Execution	Flush mount			
Material	Polycarbonate			
Mounting	Flush-mount 144x144mm (5.67x5.67")			
	IP65 on front with gasket, if mounted in class IP65 panel or better. IP20 terminals			
Degree of protection				
Dimensions (W x H x D)	mm	144 x 144 x 53.2		
Weight	g	640		

Dimensions

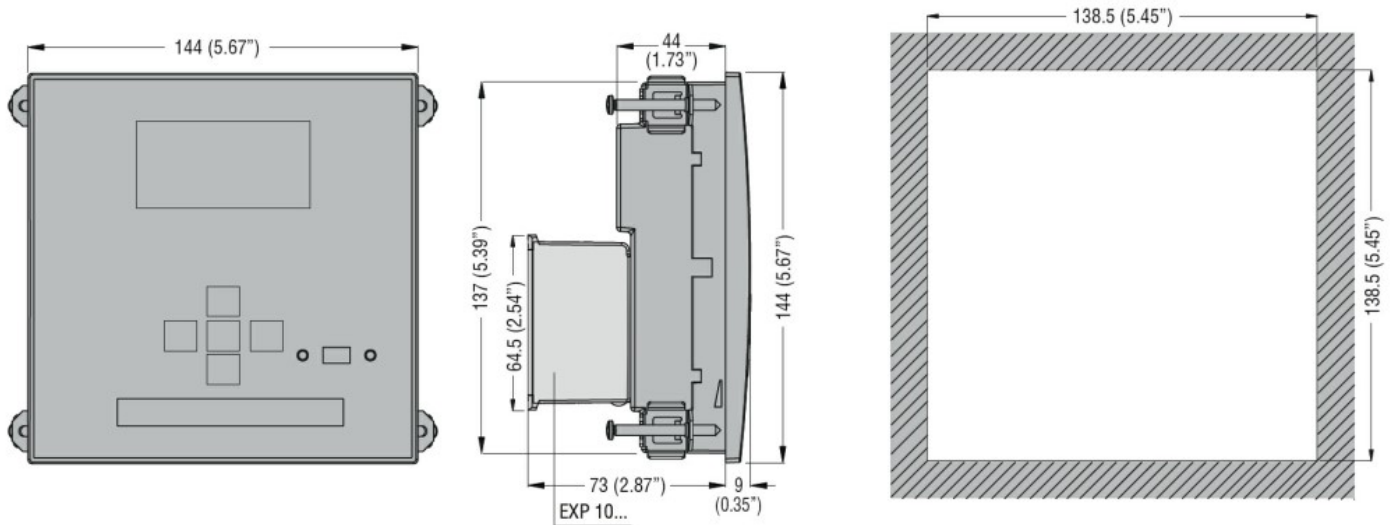

Wiring diagrams

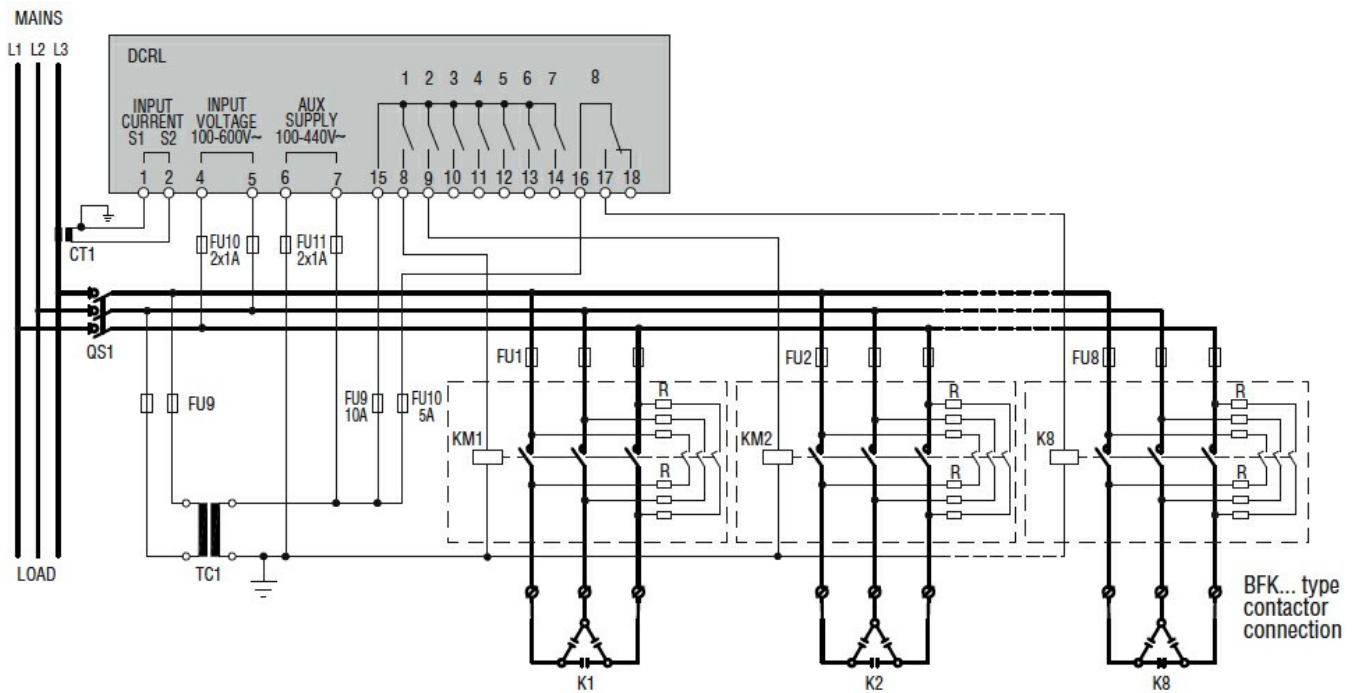

Certifications and compliance

Compliance

CSA C22.2-N°14
IEC/EN 61000-6-2
IEC/EN 61000-6-3
IEC/EN 61010-1
IEC/EN 61010-2-030
UL508

Certificates

cULus
EAC
RCM

ETIM classification

ETIM 8.0

EC001443 -
Effective power
(cos phi)
monitoring relay